

**Random Testing of
Asynchronous VLSI Circuits**

A thesis submitted to the University of
Manchester for the degree of Master of
Science in the Faculty of Science

Oleg Alexandrovich Petlin
Department of Computer Science

1994

Contents

Contents.....	2
List of Figures	5
List of Tables.....	8
Abstract	9
Chapter 1 : Asynchronous VLSI designs	13
1.1 Asynchronous versus synchronous VLSI circuits.....	13
1.2 Asynchronous design.....	15
1.3 Transition signalling.....	16
1.4 Event-controlled logic elements	19
1.5 Asynchronous micropipelines	20
1.6 Summary.....	23
Chapter 2 : Testing VLSI circuits	24
2.1 Problems in testing VLSI circuits.....	24
2.2 Fault models for VLSI circuits	25
2.3 Logic testing of VLSI circuits	28
2.3.1 Test generation methods	29
2.3.2 Response evaluation techniques	33
Chapter 3 : Pseudo-random testing of VLSI circuits	36
3.1 Generating pseudo-random patterns.....	36
3.2 Exhaustive and pseudo-exhaustive testing of VLSI circuits	42
3.3 Signature analysis.....	44
Chapter 4 : Design for testability of VLSI circuits	48
4.1 What is design for testability?.....	48
4.2 Ad-hoc techniques	49
4.3 Structured approaches	51
4.3.1 Scan path.....	52
4.3.2 Level-sensitive scan design	53
4.3.3 Scan/set technique	55
4.3.4 Random access scan	56
4.4 Built-in self-test.....	57

4.4.1 InSitu self-testing.....	58
4.4.2 ExSitu self-testing.....	61
4.5 Summary.....	63
Chapter 5 : Testing asynchronous VLSI designs - related works	65
5.1 Problems with testing asynchronous VLSI circuits.....	65
5.2 Testing bounded-delay circuits.....	66
5.3 Testing delay-insensitive circuits	75
5.4 Testing speed-independent networks	77
5.5 Testing micropipelines	78
Chapter 6 : Asynchronous random testing interface	82
6.1 Asynchronous implementations of PRPG and signature analyser	82
6.1.1 Asynchronous PRPG	83
6.1.2 Asynchronous signature analyser	84
6.2 Generating patterns for the random testing of asynchronous VLSI circuits	85
6.2.1 Generating equiprobable test patterns	85
6.2.2 A PRPG for weighted test patterns.....	91
6.3 Program tools for the behavioural simulation of PRPGs	92
Chapter 7 : Test lengths for random testing of micropipelines	96
7.1 Test length for random pattern testing.....	97
7.2 Test length for random testing using weighted patterns.....	103
7.3 Summary.....	110
Chapter 8 : Special aspects of random testing of asynchronous circuits.....	111
8.1 Probabilistic properties of the Muller-C element.....	111
8.2 Random testing of asynchronous control circuits	114
8.2.1 Random testing of the Muller-C element	114
8.2.2 Random testing of a certain class of asynchronous circuits	116
8.3 Generating patterns for the pseudo-random testing of micropipelines and asynchronous control circuits	122
Chapter 9 : Conclusions and further work	125
9.1 Conclusions	125
9.2 Future work	128
Appendix A : Asynchronous 4-bit PRPG	130

A.1 Schematic of the generator	130
A.2 The register of the generator.....	131
A.3 Simulation results	132
Appendix B : Asynchronous 4-bit parallel signature analyser.....	133
B.1 Schematic of the signature analyser.....	133
B.2 The register of the signature analyser	134
B.3 Simulation results	135
References	136

List of Figures

Figure 1.1: The standard bundled data interface.....	17
Figure 1.2: Two-phase transition signaling.....	18
Figure 1.3: Four-phase transition signaling	18
Figure 1.4: An assembly of basic logic modules for events	20
Figure 1.5: A computation micropipeline.....	21
Figure 1.6: An asynchronous sequential circuit.....	22
Figure 2.1: NMOS NOR gate with four faults.....	26
Figure 2.2: Delay fault hazard in an asynchronous VLSI circuit.....	28
Figure 2.3: VLSI logic testing.....	29
Figure 2.4: Path sensitization technique	31
Figure 2.5: Stored response testing.....	33
Figure 2.6: Comparison testing.....	34
Figure 2.7: Compact testing	34
Figure 3.1: Linear feedback shift register	37
Figure 3.2: Modular realization of a LFSR.....	37
Figure 3.3: Four-bit PRPG	38
Figure 3.4: A modified four-stage LFSR.....	43
Figure 3.5: General structure of a signature analyser	45
Figure 3.6: Four-stage serial signature analyser	45
Figure 3.7: Four-stage parallel signature analyser.....	46
Figure 4.1: Improving VLSI testability using (a) demultiplexers; (b) multiplexers	49
Figure 4.2: Using shift registers for improving (a) control access; (b) observation access	50
Figure 4.3: Huffman model for a sequential circuit.....	51
Figure 4.4: The principle of scan path techniques	52
Figure 4.5: Polarity hold latch (a) symbolic representation; (b) implementation in NAND gates.....	53
Figure 4.6: LSSD structure	54
Figure 4.7: Scan/Set configuration.....	55
Figure 4.8: Random access scan structure	56

Figure 4.9: Taxonomy of self-test approaches.....	57
Figure 4.10: Basic BILBO element.....	58
Figure 4.11: Self-testing structure with BILBOs.....	59
Figure 4.12: ExSitu self-testing structure.....	61
Figure 4.13: LOCST test structure.....	61
Figure 4.14: ExSitu STUMPS approach.....	63
Figure 5.1: Modifying sequential circuit S into a) its acyclic counterpart; b) corresponding iterative combinational circuit.....	67
Figure 5.2: R-S flip-flop realized using NAND gates.....	69
Figure 5.3: Equations for handling faults in a NAND circuit for the case of a) stuck-at-0 fault at the output; b) stuck-at-1 fault at input a.....	70
Figure 5.4: An example of untestable a) and testable b) asynchronous reset network.....	72
Figure 5.5: Testing asynchronous reset network: a) synchronous model; b) asynchronous model.....	72
Figure 5.6: Event controlled latch.....	80
Figure 6.1: Asynchronous random testing interface with the two-phase bundled data convention.....	83
Figure 6.2: An asynchronous version of a pseudo-random pattern generator.....	83
Figure 6.3: An asynchronous implementation of a signature analyser.....	85
Figure 6.4: Asynchronous logic with a latch.....	86
Figure 6.5: An example of asynchronous circuit with undetectable faults.....	87
Figure 6.6: The 6-bit PRPG based on using the 8-th state from the state modification table of the 6-bit LFSR.....	90
Figure 6.7: A general structure of a PRPG with given signal probabilities on its outputs.....	91
Figure 6.8: A general structure of the universal PRPG.....	93
Figure 6.9: A WPRPG built by using ROMs.....	94
Figure 6.10: A PRPG of weighted patterns based on using additional logic elements.....	95
Figure 7.1: Random testing of logic blocks of micropipelines.....	97
Figure 7.2: Random testing a combinational logic block.....	98
Figure 7.3: The Markov chain describing the process of the appearance of two different random patterns.....	104
Figure 7.4: A graph of the dependence between the relative error and the escape probability.....	108
Figure 8.1: An implementation of the two-input Muller-C element.....	111

Figure 8.2: An example of an asynchronous logic block.....	117
Figure 8.3: An asynchronous logic circuit for random pattern testability	120
Figure 8.4: PRPG used for testing micropipelines.....	122
Figure A.1: An asynchronous implementation of the 4-bit PRPG	130
Figure A.2: An implementation of the 4-bit register of the generator	131
Figure A.3: The results of the behavioural simulation of the generator	132
Figure B.1: An asynchronous implementation of the 4-bit parallel signature analyser	133
Figure B.2: An implementation of the register of the signature analyser	134
Figure B.3: The results of the behavioural simulation of the signature ana- lyser.....	135

List of Tables

Table 2.1: The truth table of NMOS NOR gate with four faults	26
Table 3.1: State sequence for the four-bit PRPG	39
Table 3.2: Primitive polynomials for different n from 1 to 33	41
Table 5.1: Equations for an R-S flip-flop	70
Table 6.1: State modifying table for the 4-bit LFSR	87
Table 6.2: State sequence for the four-bit PRPG built using the state modification procedure.....	88
Table 6.3: Table of equivalence between states of the three 4-bit PRPGs.....	89
Table 6.4: State modifying table for the 6-bit LFSR	90
Table 7.1: Statistical and theoretical random lengths for the exhaustive testing of combinational networks.....	102
Table 7.2: Numerical solutions of inequalities (17) and (18)	107
Table 7.3: Theoretical and experimental results for estimating the test lengths for random pattern testing of a 3-input combinational circuit	109
Table 8.1: Equations for calculating theoretical probabilities of a one and zero of basic logic elements.....	120
Table 8.2: State sequence for the two-bit PRPG.....	123

Abstract

Asynchronous VLSI designs are becoming an intensive area of research due to their advantages in comparison with synchronous circuits, such as the absence of the clock distribution problem, lower power consumption and higher performance.

The work described in this thesis is an attempt to find possible ways to test asynchronous VLSI circuits using random (or, more accurately, pseudo-random) patterns. The main results have been obtained in the field of random testing of stuck-at faults in micropipelines.

An asynchronous random testing interface has been designed which includes an asynchronous pseudo-random pattern generator and an asynchronous parallel signature analyser. A program model of the universal pseudo-random pattern generator has been developed. The universal pseudo-random pattern generator can produce multi-bit pseudo-random sequences without an obvious shift operation and it can also produce weighted pseudo-random test patterns.

Mathematical expressions have been derived for predicting the test length for random pattern testing of logic blocks of micropipelines by applying equiprobable and weighted random patterns to the inputs.

The probabilistic properties of the n -input Muller-C element have been investigated. It is shown that the optimal random test procedure for the n -input Muller-C element is random testing using equiprobable input signals. Using the probabilistic properties of the Muller-C element and multiplexers incorporated into the circuit a certain class of asynchronous networks can be designed for random pattern testability. It is also shown how it is possible to produce pseudo-random patterns to detect all stuck-at faults in micropipelines.

Declaration

No portion of the work referred to in this thesis has been submitted in support of an application for another degree or qualification of this or any other university or institute of learning.

Copyright in text of this thesis rests with the Author. Copies (by any process) either in full, or of extracts, may be made **only** in accordance with instructions given by the Author and lodged in the John Rylands University Library of Manchester. Details may be obtained from the Librarian. This page must form part of any such copies made. Further copies (by any process) of copies made in accordance with such instructions may not be made without the permission (in writing) of the Author.

The ownership of any intellectual property rights which may be described in this thesis is vested in the University of Manchester, subject to any prior agreements to the contrary, and may not be made available for use by third parties without the written permission of the University, which will prescribe the terms and conditions of any such agreement.

Further information on the conditions under which disclosures and exploitation may take place is available from the Head of Department of Computer Science.

Acknowledgements

During the last year I have received a great help from many people, without which the work described in this thesis would have been very difficult or even impossible.

My supervisor Professor Steve Furber has been a great source of inspiration and moral support. I would like to express my gratitude for his constant interest in my ideas and research results and for correcting and commenting on drafts of this thesis.

The other members of the AMULET research group have created a very friendly and comfortable atmosphere for me to lead my research. I would like to thank all of those people who have spent their valuable time to help me to understand asynchronous VLSI designs.

I am especially grateful to Phil Endecott for his help and useful tips with GCC and FrameMaker, and Dr. Jim Garside for providing assistance with Powerview CAD tools.

Some people have helped by reading and commenting on drafts of this thesis as well. I must express my thanks to Phil Endecott for his useful comments.

The Author

Oleg Petlin obtained an Engineer degree (1989) and a Candidate of Technical Sciences degree (1993) in Computer Science from Kiev Polytechnical Institute (Ukraine). This thesis is the result of the first year of research as a member of the AMULET research group at the University of Manchester.

AMULET (Asynchronous Microprocessor Using Low Energy Techniques) comprises four projects looking at different areas where asynchronous logic techniques can be applied.

Chapter 1 : Asynchronous VLSI designs

1.1 Asynchronous versus synchronous VLSI circuits

The combination of recent developments in the technology for producing digital circuits with powerful computer-aided design (CAD) tools [1, 2] has given designers new opportunities to create circuits with high performance and high density of logic elements in the form of very large scale integrated (VLSI) circuits.

Almost all today's VLSI circuits and systems are designed using two major conceptual rules: information is represented in a binary format, and time is discrete. In general, this is an artificial approach to designing digital circuits which is used because it avoids many of the problems concerned with representing and processing digital information. Usually such VLSI circuits use a common clock signal distributed through the design to control the timing and sequencing of the data flow. In such synchronous VLSI circuits, hazards can be ignored simplifying the digital design process.

A VLSI circuit is a system of a large number of interconnected elements where a sequence of events is realized. The most natural discipline for processing information in digital systems is asynchronous, i.e. each element processes data in response to new information being delivered to its inputs. The combination of an asynchronous discipline for controlling the sequence of handling digital information with VLSI technology creates new possibilities for designing VLSI circuits with new features and advantages [3, 4, 5, 6, 7]. There are some general benefits of using asynchronous designs in comparison with synchronous ones:

- *The clock skew problem.* The clock skew problem appears when it is necessary to synchronize different parts of a VLSI system. This synchronization cannot be completely accurate for the simple reason the clock signal arrives at different parts of the

VLSI circuit at different times, due to different track lengths. Asynchronous circuits by definition have no common clock and, therefore, have no clock skew problem.

- *Metastability problem.* It is known that for a successful computation process the data must be valid before being clocked. If this condition is not obeyed a synchronous circuit can go into an unstable equilibrium which is called a metastable state. Thus, the exact values of the delays of elements must be known to ensure correct synchronization. Asynchronous elements can have arbitrary delays and can wait an arbitrary time while input information stabilizes.
- *Performance.* The performance of synchronous VLSI systems is limited by the worst case when an element processes information for the longest time. As a rule, this situation is rare but must be taken into account to avoid the metastability problem. Asynchronous VLSI circuits operate at a rate determined by element and wiring delays. As a result the performance rate tends to reflect the average case delay rather than the worst case delay.
- *Power consumption.* Synchronous VLSI circuits are designed in such way that even if some parts of the circuit are not involved in a computation process they have to be clocked, i.e. they perform their functions with data which is not in use. In contrast, in asynchronous VLSI designs only those parts of the circuit which produce “useful” information take part in the computation. This property of asynchronous designs leads to power savings in VLSI circuits.
- *Timing and design flexibility.* If a designer of a synchronous VLSI circuit is required to make a circuit work at a higher clock frequency, all parts of the circuit must be improved because of the worst-case performance property. In the case of asynchronous designs the problem can be solved if only “the most active” parts of the circuits are modified. These modifications can be implemented using new developments in VLSI technology. In general, greater throughput for synchronous circuits can be achieved only when all VLSI components are realized on a new technology because the critical (longest) path can go through all the elements of the VLSI circuit.

Besides the advantages, asynchronous circuits also have some disadvantages. It appears to be difficult to design asynchronous VLSI circuits for specific applications. The designers must pay great attention to the dynamic properties of asynchronous circuits and to the control of the sequence of operations. The lack of powerful CAD tools makes it difficult to design asynchronous VLSI circuits. Nevertheless, the scope of asynchronous designs is wider than that of synchronous ones. This encourages designers to do more research in the field of creating productive asynchronous VLSI circuits.

1.2 Asynchronous design

In general synchronous designs can be seen as a particular case of representing data processing designs in the multi-dimensional asynchronous world [2]. There are many different approaches to designing asynchronous VLSI circuits. Nevertheless, the most popular design approaches currently in use can be categorized by the way data is represented and processed [4]:

- *Data representation.* Data in asynchronous designs can be represented either by using a dual rail encoding technique or a data bundling approach. In the dual rail encoded data representation, each boolean variable is represented by two wires. Here the data and timing information are carried by each wire. The data itself can be represented by logic levels (a one is represented by a high voltage and a logic zero by a low voltage) or by transition encoding where a change of signal level conveys information. The bundled data approach uses one wire for each data bit and a separate control wire containing the timing information.
- *Data processing.* There are three basic models for data processing in asynchronous designs. **Delay-insensitive** circuits make no assumptions about delay within the VLSI design, that is any logic element or interconnection may take an arbitrary time to propagate a signal. **Speed-independent** circuits assume that the logic elements of the VLSI design may have an arbitrary propagation delays but transmission along wires is instantaneous. In **bounded-delay** asynchronous circuits, all delays within the circuit (caused either by logic elements or wires) are finite.

In circuits using dual-rail encoding with transition signalling, a transition on one of the two wires indicates the arrival of a zero or one. The signal levels are not taken into account. Such circuits can be fully delay-insensitive. They possess the greatest flexibility to improve the design performance by replacing logic elements with their faster versions.

Another popular asynchronous design style uses dual-rail encoding with level sensitive signalling [6]. In comparison with the previous case such designs require a “return to zero” phase in each transition which causes more power dissipation. Nevertheless, the realization of logic elements processing logic levels is simpler than transition processing logic.

Ivan Sutherland described an approach to designing asynchronous circuits called “micropipelines” [3]. This approach uses bundled data with transition signalling to form a handshake protocol to control data transfers. Using the micropipeline approach, the AMULET group in the Department of Computer Science at the University of Manchester has designed an asynchronous implementation of the ARM6 microprocessor architecture and has successfully run an ARM validation suite that tests all the major instruction types used in the architecture [5]. Silicon layout is complete, and the design is fabricated. Considered at the highest level, the asynchronous ARM is one large micropipeline that takes in a stream of data and instructions and outputs a stream of addresses and processed results. Internally, many of the ARM’s subunits also behave as micropipelines. For example, the data path is a three-stage micropipeline which contains the register bank, the shifter/multiplier and the ALU [7]. As an extension of this work, the solution of test problems of micropipelined structures becomes an interesting topic of research.

1.3 Transition signalling

In micropipelined asynchronous designs, every signal transition (falling or rising) is associated with an event. Compared with a pulse, a signal transition is the most economical representation of an event because the width and level of a pulse are more difficult

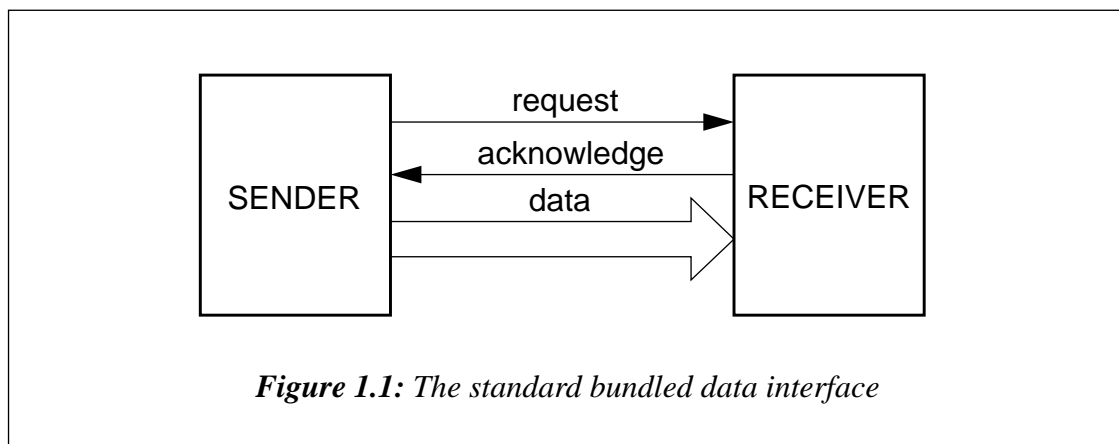

to distinguish than a signal transition. Using transitions to indicate events it is possible to control the sequence of operations in an asynchronous design. The standard handshaking convention between a sender and a receiver includes at least two control wires: request and acknowledge (Figure 1.1). First, the sender generates data for the receiver. Once the data signals have reached their stable (conventional low and high) states the sender produces the request signal to indicate that the data value is available. The receiver captures the data and generates on its acknowledge wire a transition to indicate that the data have been accepted. There is a strict sequence of three basic events in this handshaking mechanism: data change, request and acknowledge. The sequence of events in such an asynchronous communication protocol can be continued infinitely by repeating the basic events. The data are operated on as a bundle when the levels of all signals on the data wires reached their stable levels.

Two transition signalling schemes for the bundled data convention are known [2]. These are two-phase (or two-cycle) and four-phase (or four-cycle) signalling protocols. In the two-phase bundled data convention depicted in Figure 1.2 there are two active phases in the communication process: these are the signal transitions (rising or falling) on the request and acknowledge wires. An event on the request (acknowledge) control line terminates the active phase of the sender (the receiver). During the receiver's active phase the sender must hold its data unchanged. Once the receiver generates an acknowledge event new data can be produced by the sender. In Figure 1.2 solid (dashed) lines represent the sender's (the receiver's) actions.

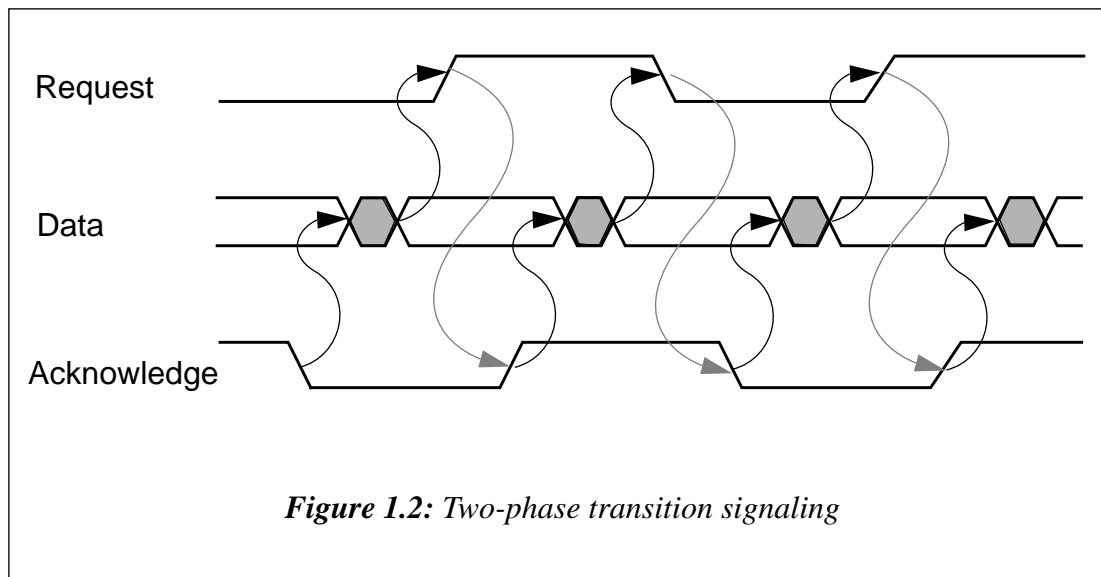
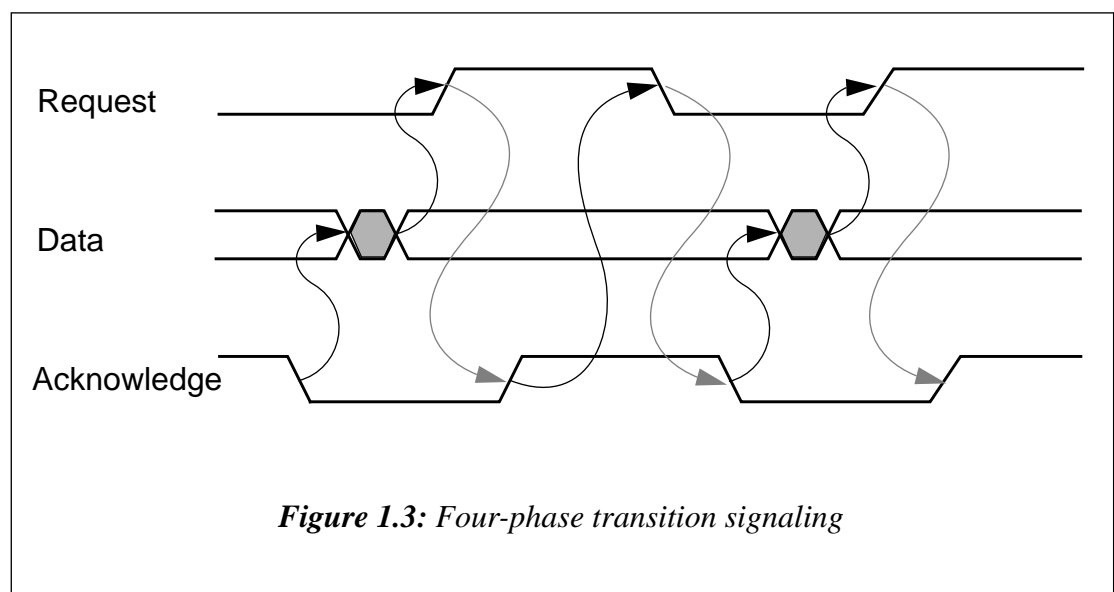

Figure 1.3 shows the four-phase bundled data convention which uses four active phases in the communication protocol. Each pair of rising and falling signal transitions on the request (acknowledge) wire terminates the sender's (receiver's) active phase.

Each form of signalling has advantages and disadvantages. For example, the four-phase bundled data convention requires twice as many signal transitions as the two-phase convention. As a result, four-phase signalling can be used without serious performance penalties in VLSI systems only where wire delays between elements are negligible. In the



two-phase bundled data convention the interpretation of transitions requires more control logic than four-phase signalling requires.

1.4 Event-controlled logic elements

Asynchronous circuits which use transition signalling protocols for controlling data flow require basic control building blocks which differ from synchronous ones. All event-controlled logic elements are bistable digital circuits which form various logical combinations of events. Figure 1.4 shows an assembly of the most frequently used asynchronous logic modules for events [3].

The simplest module is the **Exclusive-OR (XOR)** element which has a function equivalent to merging two events: if an event is received on either of the inputs of an XOR element a response event will be produced on the output of the element.

The **Muller C-element** performs a logical AND of input events. When all the inputs of a Muller C-element are ones (zeros) the Muller C-element generates an one (zero) on its output and stores this state. If the inputs are different the Muller C-element retains its previous state and holds the output unchanged. Therefore, the Muller C-element produces an event when an event takes place on each its input. Because of this property the Muller C-element is sometimes called a “rendezvous” circuit.

The **Toggle** circuit sends a transition alternately to one or other of its outputs when an event appears on its input. The first event is generated on the dotted output.

The **Select** module is a demultiplexer of two events. It steers a transition to one of two outputs depending on the logical value on its diamond input.

The **Call** element serves a function which is similar to a subroutine call in programming. It remembers which one of its two inputs received an event first, r_1 or r_2 , and calls the procedure, r . After the procedure is finished, d , the Call element produces a matching done event on d_1 or d_2 output.

The **Arbiter** guarantees that both of its outputs are not active at the same time. The arbitration function is in granting service, g_1 or g_2 , to only one request, r_1 or r_2 , at a time. The other grant is delayed until after an event has taken place on the done wire, d_1 or d_2 , corresponding to the earlier grant.

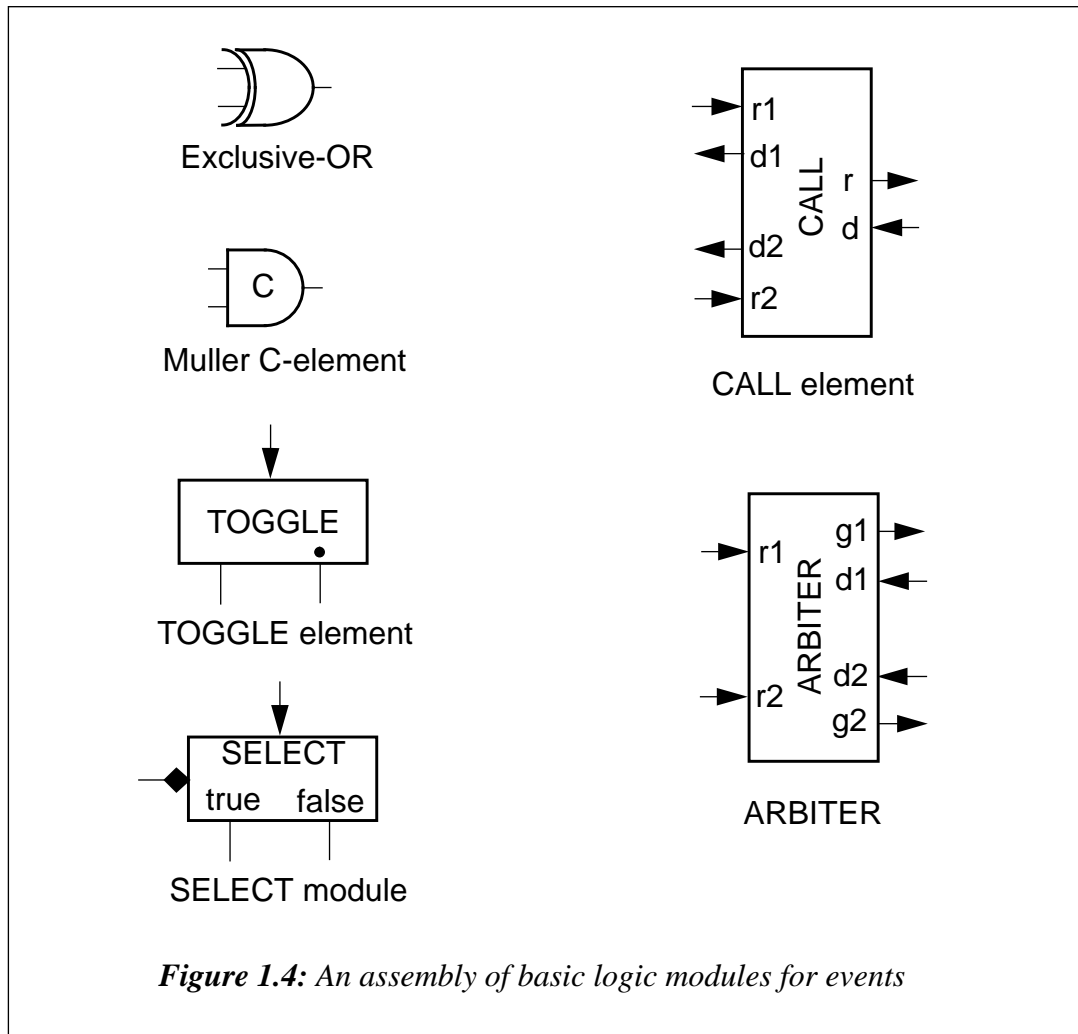

1.5 Asynchronous micropipelines

A pipeline is a mechanism used for speeding up the throughput in a computer system. The main reason for using pipelines is to increase the number of elements doing computations at a given time. A micropipeline is a data processing pipeline whose stages operate asynchronously. There are several papers which describe basic principles for designing asynchronous micropipelines [3, 5]. Figure 1.5 represents the general struc-

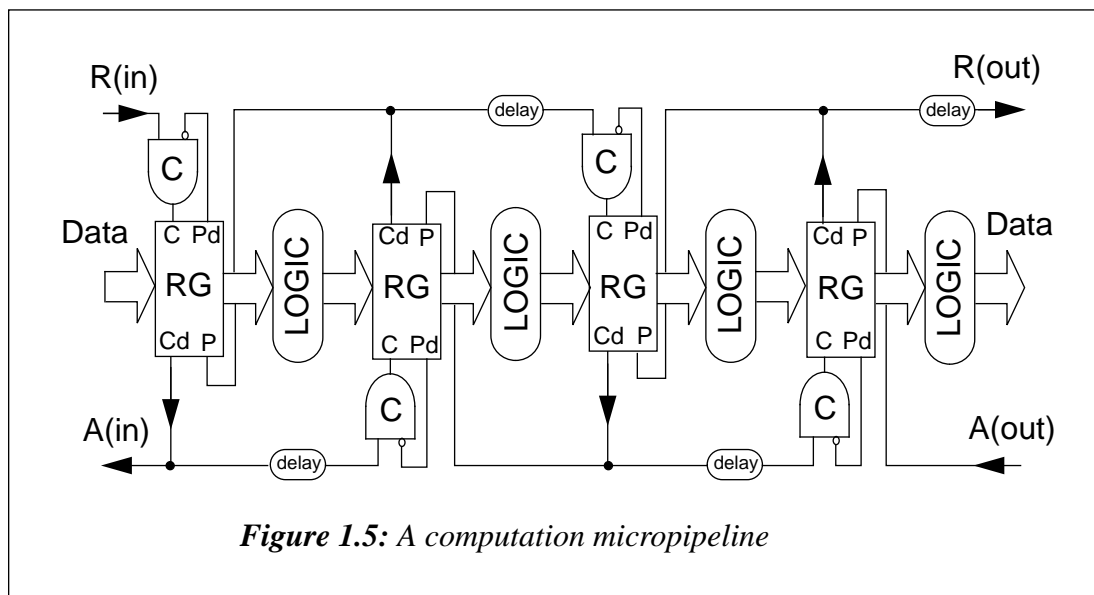

ture of a two-phase micropipeline incorporating computation. The registers in the picture are similar to level sensitive latches which are usually used in synchronous designs. The only difference is that they respond to transitions on two inputs instead of a single clock wire. Initially all registers pass data directly from their inputs to outputs. When a transition takes place on the **C** (capture) control input the current binary vector is latched in the register. Once a transition occurs on the **P** (pass) wire the register returns to a transparent state and the computation cycle repeats. The register output **Cd** (**Pd**) is the capture-done (pass-done) output on which a delayed version of the capture (pass) event is generated. If a transition is stored in the FIFO control logic the data will be buffered in the registers. Since each computation logic block has its internal delay the **Cd** signal transition must be delayed by as much as the worst-case logic block delay. Without the logic blocks the micropipeline (Figure 1.5) is a FIFO buffer.

Using the same approach to designing micropipelines an asynchronous sequential circuit can easily be produced. Figure 1.6 shows the basic structure of such a circuit. This structure uses two registers, **RG1** and **RG2**; register **RG1** holds the previous state of the circuit and the new state is stored into register **RG2**. In the initial state the initial binary vector is written into **RG1**. As a result a high voltage level is generated on the **Cd** output of **RG1**, **Pd** output of **RG2** and the acknowledge output of the circuit, **A(in)**. The

request event is produced by the sender when the primary inputs, PI, are stable. The request signal is delayed for sufficient time to ensure stable levels on the internal and primary outputs, PO, of the logic block. After storing the new state of the sequential circuit into RG2 the request event for the receiver is formed on the Cd output of RG2. After the acknowledge event on the A(out) wire takes place the new state is copied from RG2 to RG1 and the circuit produces the acknowledge signal transition for the sender. Thus, after a new request event from the sender is registered the computation cycle of the sequential circuit is repeated.

A major advantage of the micropipeline structure is the possibility of filtering out all hazards in the logic blocks. Another positive feature is that an asynchronous micropipeline is automatically elastic; that is, data can be sent to and received from a micropipeline at arbitrary times. Although micropipelines are a powerful tool for implementing elastic pipelines they have one serious drawback. The micropipeline approach is inherently bounded-delay rather than delay-insensitive. In order to yield a completely delay-insensitive system the timing information must be encoded with the data itself.

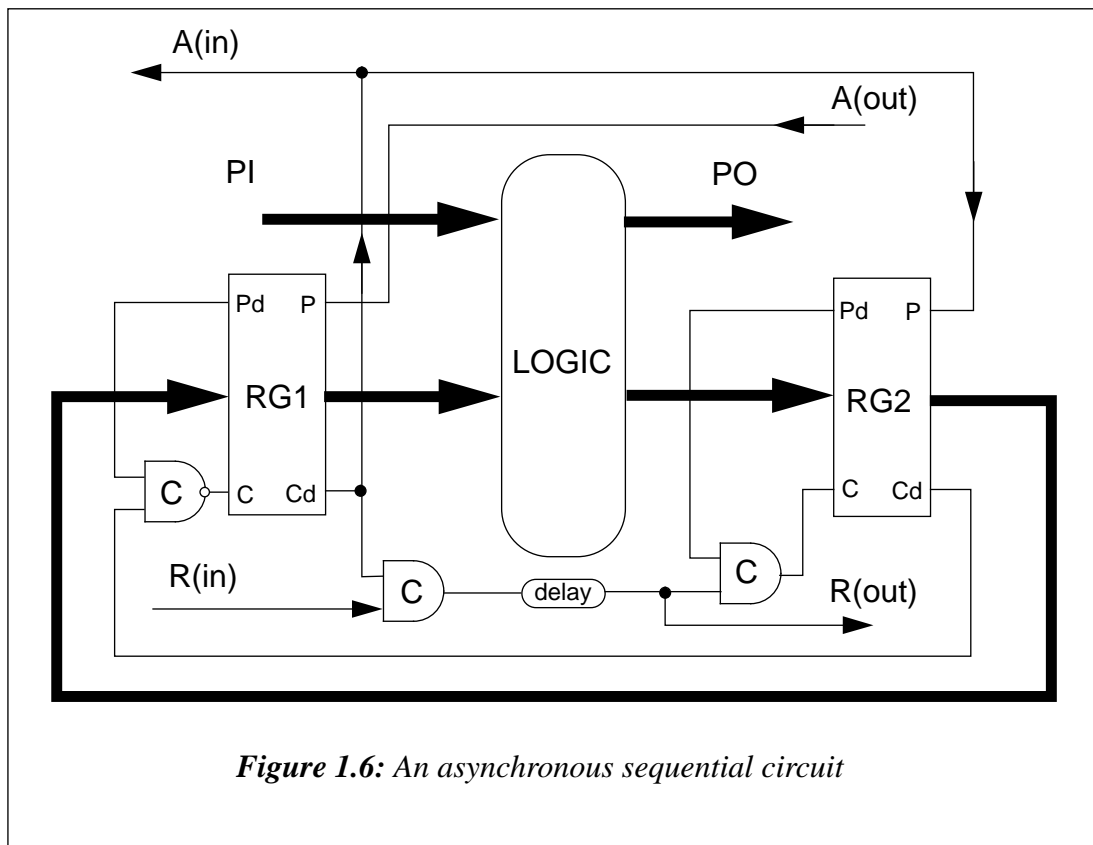

Figure 1.6: An asynchronous sequential circuit

1.6 Summary

Asynchronous VLSI circuits are becoming a serious alternative to synchronous circuits because of the absence of global clock distribution. One of the most attractive models to implement asynchronous circuits is the bounded-delay model. Specifically, it is assumed that the delay in all circuit elements and wires is known, or at least bounded. Such asynchronous circuits can be designed easily using fundamental principles for designing synchronous hardware and a pipelined approach. Unfortunately, bounded-delay asynchronous circuits are complex systems where multiple control state machines and data path elements are combined to implement the desired function. This leads to specific difficulties in solving the fault detection problem, which is the subject for discussion in the following chapters.

Chapter 2 : Testing VLSI circuits

2.1 Problems in testing VLSI circuits

The ability to put millions of transistors on a single chip of silicon creates great potential for reducing power, increasing speed, and drastically reducing the cost of VLSI circuits. Unfortunately, several serious problems must be solved in order to exploit these advantages. The main problem is that of identifying faulty and fault-free VLSI designs before and after fabrication. A large number of CAD tools has been developed to help design engineers do logic and design verification [1, 2, 8, 9]. Several test generation algorithms have been devised to detect faulty VLSI circuits after their physical implementation [9-14]. The major problems which make the testing of either synchronous or asynchronous VLSI circuits difficult or even impossible are:

- Test generation and testing time and consequently testing costs are increasing rapidly with increasing VLSI circuit complexity. The increasing complexity of VLSI circuits causes the controllability of the inputs and the observability of the outputs of VLSI elements to be more and more problematic. At the same time the sequential depth of VLSI circuits is increasing. It has been shown that the cost for test generation increases as an exponential function of the sequential depth of the network [11].
- In order to test VLSI circuits test engineers have to deal with enormous amounts of diagnostic information which demands the use of complex and expensive test equipment.
- Rapid changes in VLSI technology create the possibility of physical defects manifesting themselves in a large number of ways. In some cases traditional fault models for such circuits cannot be used to determine the fault coverage of test patterns.

- The Application Specific Integrated Circuit (ASIC) market requires design engineers to produce VLSI circuits as quickly as possible, reducing the time for estimating the testability of new products. The low production volumes of ASICs makes test costs a significant part of the overall costs.

2.2 Fault models for VLSI circuits

A VLSI circuit failure occurs when the circuit produces output information which deviates from the result which is defined by the specification. The failure occurs because the VLSI circuit is erroneous, i.e. there is an error in part of the circuit which leads to failure. The cause of the error is a fault. Thus, an error is the manifestation of a fault in the VLSI circuit, and a failure is the effect of an error. In VLSI circuits all faults can be divided into two classes [9]: physical faults and human-made faults, which may be defined as follows:

- *physical faults*: adverse physical phenomena, either internal (physico-chemical disorders: threshold changes, short circuits, open circuits, etc.) or external (changes in environmental conditions: electromagnetic perturbations, temperature, vibrations, etc.);
- *human-made faults*: imperfections which are design faults or interaction faults caused by violations of operating or maintenance procedures.

A fault model is a description of the effect of a physical fault in a circuit. Test engineers need to have as near as possible exact fault models for the derivation of high-quality tests and fault simulations. The most useful fault models which can manifest themselves by affecting the logical behaviour of both asynchronous and synchronous VLSI circuits are stuck-at faults, bridging faults, stuck-open faults and delay faults [9, 15-17].

The stuck-at fault model. This fault model is one of the most widely used. The stuck-at fault model assumes that faults will result in the wires at the logic gate level of the circuit being permanently logic zero (stuck-at-0) or one (stuck-at-1). This model is still used since many circuits' faults can be modelled by the stuck-at fault model at the logic

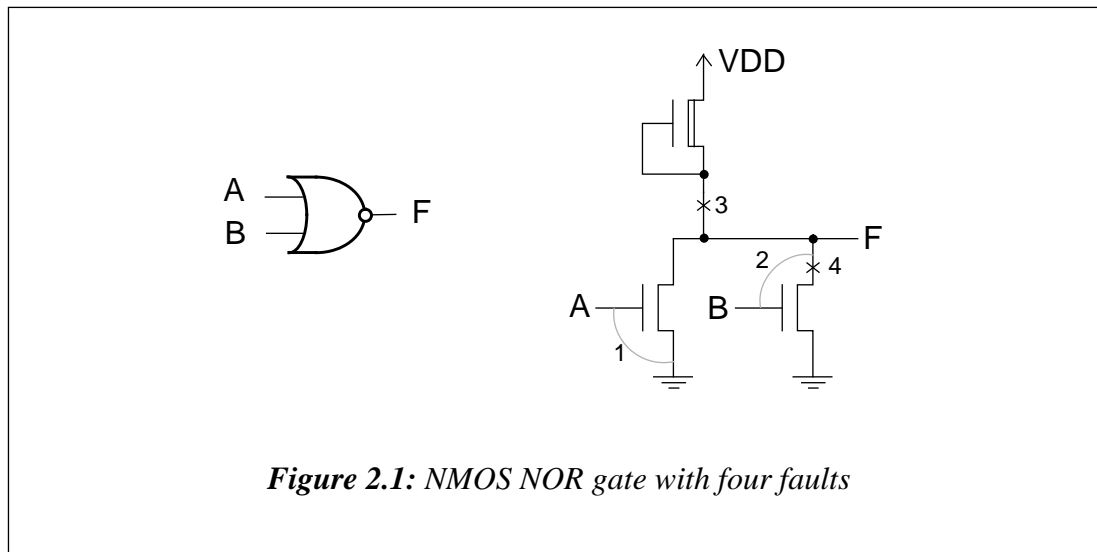

level. Theoretically, for any circuit the total number of all possible faulty circuits with multiple stuck-at faults can be estimated as $3^n - 1$, where n is the number of nodes in the circuit. In practice, only single stuck faults are considered in order to eliminate an incredibly large number of faulty VLSI circuits.

Figure 2.1 shows an NMOS NOR gate with four faults: faults 1 and 2 being shorts (shown as dotted lines) and faults 3 and 4 being opens (depicted by crosses). Table 2.1 gives the behaviour of the gate when all possible two-bit binary vectors are applied under these four faults. Outputs are shown for no fault (F_0), for the two shorts (F_1 and F_2) and for the two opens (F_3 and F_4). Fault 1 is logically equivalent to the A input stuck-at-0 since the gate cannot be driven to logic 0 when $A=1$ and $B=0$. Fault 4 is equivalent to the B input stuck-at-1 and can be detected by applying $A=0$, $B=1$. If the

Table 2.1: The truth table of NMOS NOR gate with four faults

Inputs		Outputs				
A	B	F_0	F_1	F_2	F_3	F_4
0	0	1	1	1	Q^n	1
0	1	0	0	u	0	1
1	0	0	1	0	0	0
1	1	0	0	0	0	0

short marked 2 is present, then under the input 01, the output may not be 0 but may be an indeterminate voltage represented as u . Thus, under this fault and this input combination, the output is permanently stuck at 0 or 1. This example demonstrates that in some cases the stuck-at fault model cannot be accurate.

The bridging fault model. Bridging faults are the result of many physical faults which at the circuit level will produce shorts between interconnecting lines. In TTL technology this model treats shorts between lines in the logic gate network and assumes that all affected lines will have the wired-AND or wired-OR logic value under fault [15]. It has been shown that the bridging fault can convert a combinational circuit to a sequential one in CMOS technology [14]. This, in turn, creates extra problems in the testing of VLSI circuits.

The stuck-open fault models. These kinds of faults are inherent to MOS technology [16]. In the case of a stuck-open fault an open transistor (or a broken line) can lead to a MOS gate behaving as if it had memory. For example, fault 3 in the NMOS NOR gate (Figure 2.1) produces a high-impedance output under the combination 00 (Table 2.1). In NMOS technology this means that the gate stores the previous output (shown as Q^n) at least for a period of time until any residual charge leaks away from the output. Fault 3 can manifest itself on the output of the gate only under a certain sequence of input combinations. If two input vectors are applied as 11, 00, then the fault will be detected since Q^n will be a 0 and the correct output should be a 1. If the 00 combination was applied first, when the output wire was 1, fault 3 would not be detected.

Delay faults. A delay fault is a fault on an element or path that alters its delay. In synchronous VLSI circuit such a fault would require the chip to be clocked at a slower rate. However, in an asynchronous VLSI circuit there is no clock to slow down, and a delay fault can cause incorrect circuit operation that in some particular cases cannot be fixed. For instance, in Figure 2.2, a pulse generator drives a pulse detector. The delay in the pulse detector feedback line is designed to be smaller than the pulse generator's pulse width. As a result, the pulse detector remains 1 after the first pulse is detected. If a delay fault occurs in the pulse detector delay, the feedback value may not arrive before the

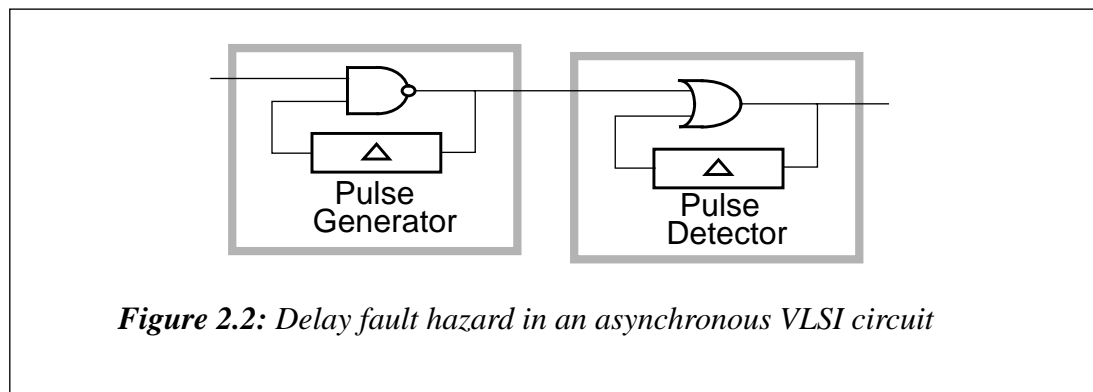

pulse has ended. Thus, the pulse detector will oscillate. Methods for detecting delay faults have been developed [17, 18]. Unfortunately, they require complex test equipment capable of applying multiple test sequences rapidly and checking data at specific times.

Although the stuck-at fault model is widely accepted by test engineers as a standard for measuring test coverage, this model is now becoming inadequate as new failure mechanisms are being discovered for VLSI circuits.

2.3 Logic testing of VLSI circuits

All test procedures assume the application of a set of patterns (“tests”) to the inputs of the circuit under test (CUT) and an analysis of the responses obtained. If the CUT produces the right outputs it means that it is fault free for the predefined class of faults. Most test methods separate the testing process from normal operation in order to provide a higher degree of fault coverage [13, 19, 20]. Basically, a test procedure includes three main steps: test pattern generation, applying the set of test patterns to the CUT, and evaluating the responses observed on the outputs of the CUT (Figure 2.3). The aim of the test pattern generation step is to derive those tests which will detect all possible faults from the set of faults. The test patterns can be applied in two ways. The first way is to use external test equipment to apply tests to the CUT and check the responses. The second way presumes the application of test patterns inside the CUT. The method of applying test patterns internally is suitable for realization in VLSI systems for arranging self-testing procedures [21]. The results of the process of evaluating the responses obtained

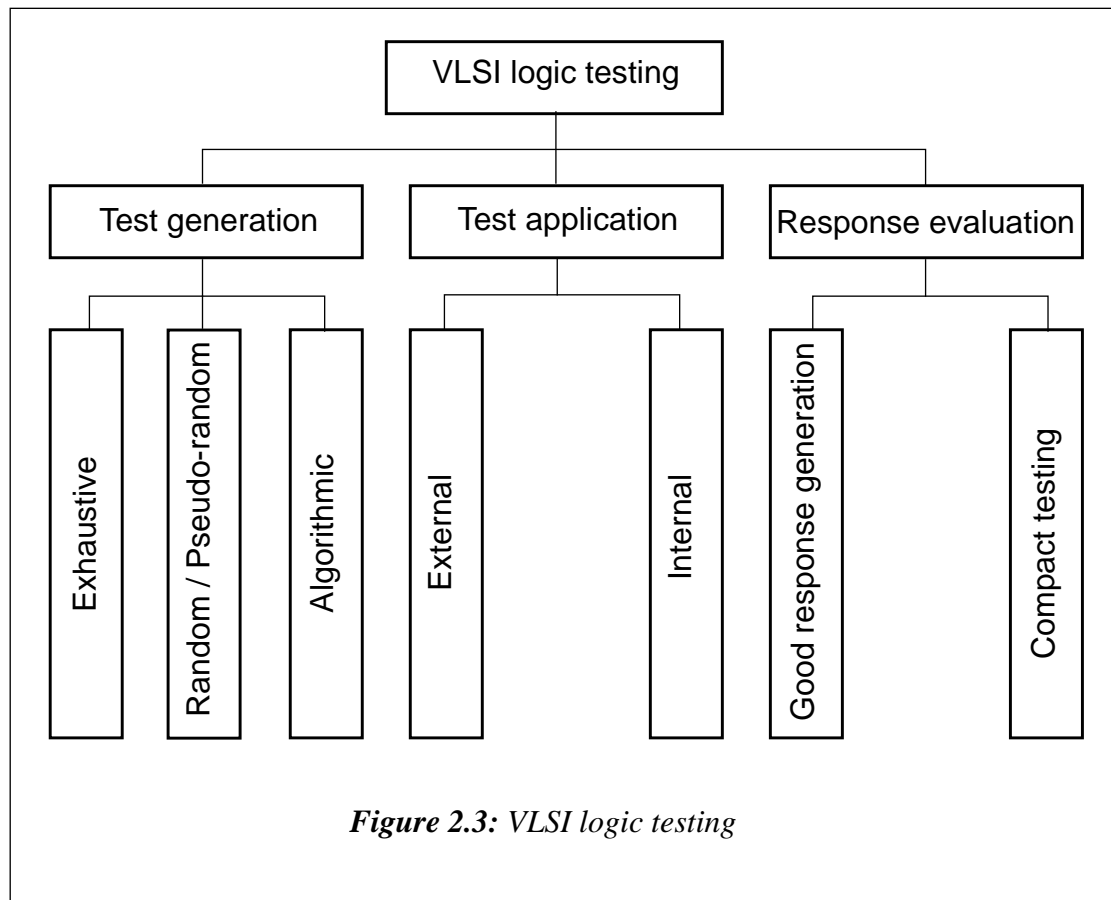

from the CUT can help to solve two test tasks: the definition of a faulty circuit (so called go/no-go testing) and, in addition to this, the indication of the position of the fault in the CUT (fault location testing) [20]. Go/no-go testing is reasonable for testing VLSI chips as a chip is a replaceable element in most VLSI systems. Both test methods can be used for testing VLSI systems.

2.3.1 Test generation methods

The main goal for the test generation process is to derive those input patterns which, when applied to the CUT, will sensitize any existing faults (the controllability problem) and propagate an incorrect response to the observable outputs of the CUT (the observability problem) [10]. A test set is good if it is capable of detecting a high percentage of faults from the possible CUT faults or simply if it can guarantee a high fault coverage. Before designing tests for a digital circuit a test engineer has to solve two problems: to

chose an appropriate descriptive model for the CUT (the description at the transistor, gate or register transfer level) and to develop a fault model to define the result of a physical fault. Obviously, the lower the level of circuit representation used in test pattern generation, the more accurate the fault model will be. However, the use of low level description languages for VLSI circuits having many thousands of transistors aggravates the problem of test pattern generation drastically. It has been shown that the problem of generating a test set for single stuck-at faults in a combinational circuit represented at the gate level is an NP-complete problem [22]. For a sequential circuit the test generation problem becomes much more difficult since the number of incorporated memory elements increases. Thus, in each particular case a test engineer must find a compromise between the time to derive the test and the level of fault coverage achieved by the test.

Basically, approaches to test generation can be divided into three groups: exhaustive testing, random (pseudo-random) testing and algorithmic test generation methods (Figure 2.3). Exhaustive testing assumes the application of all possible input vectors to the CUT. If a faulty combinational circuit has a fault which does not result in sequential circuit behaviour the application of all possible binary vectors to the inputs of the CUT can guarantee 100% fault coverage. For the exhaustive testing of a circuit with a large number of inputs the number of tests becomes incredibly large. An approach to extending the exhaustive test technique to large circuits by means of partitioning the CUT into subcircuits any of which can be tested for a reasonable time has been described [23]. However, this approach has a major problem concerned with finding the most suitable partitions.

In random (pseudo-random) testing [14, 24, 25], input vectors are produced with the help of random (pseudo-random) test pattern generators. The reactions of the faulty and the fault-free circuits for each random vector are compared using a simulator. If the responses are different the current vector is put into a test set. The main advantage of all random (pseudo random) generation techniques is that the test engineer has a source of test patterns and only the problem to be solved is that of proving that the random test set has the desired fault coverage.

Many algorithms have been proposed [9-14] for generating test vectors for either combinational or sequential circuits. The majority of these methods generate test sequences by means of analysing the topological structure of the CUT. Such well-known path sensitization algorithms as the D-algorithm [10], PODEM [14] and FAN [9] have successfully been used for automatic test generation for VLSI circuits.

The concept of the path sensitization technique is illustrated in Figure 2.4. The derivation procedure for the stuck-at fault on line d includes three sequential steps marked by circled numbers. The goal of the first step is to set line d to 0. In Figure 2.4 the logical value before the slash is the correct value for the fault-free circuit; the value after the slash is the logical result in the faulty circuit. On the second step, line a should be set to 0 in order to justify the previous step. The last test generation step makes the effect of the fault on line d propagate to the output e by setting line b to 0. As a result, test pattern 00 can be applied to detect the stuck-at-1 fault on line d.

As shown above, the main point of path sensitization algorithms is in analysing the circuit topology in order to construct an input vector which will sensitize a path from the fault site to a primary output. The process of path sensitization consists of three basic operations: justification, implication and propagation [13]. Step 2 of the above example is justification for generating a logical 0 on node d. In general, when a value is assigned to a certain node, it may imply other logical values for some lines of the circuit. The aim of the implication procedure is to cause forward propagation of the result of the justification step. For example, a logical 0 can be set on line d by setting a logical 1 on line b (see Figure 2.4). In this case the effect of the fault on line d cannot be propagated

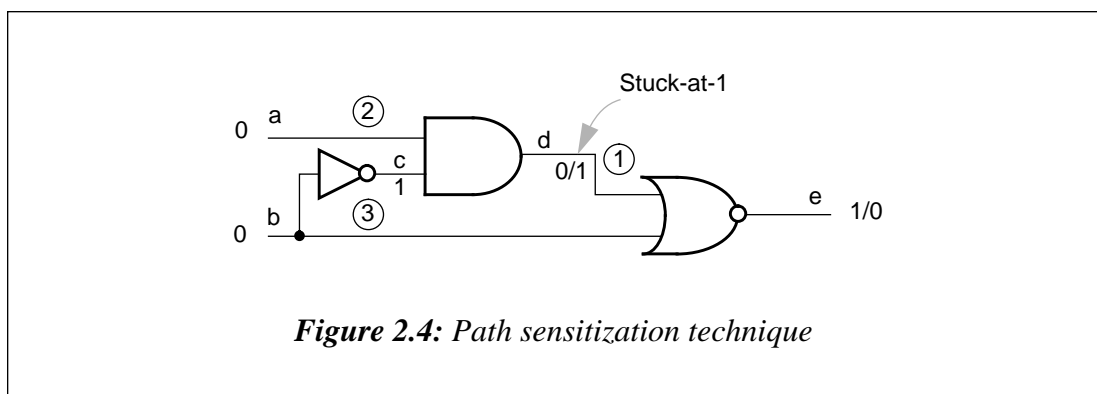

Figure 2.4: Path sensitization technique

through the NOR gate to the output e . Therefore, the result of the justification step can be propagated only if a logical 0 is set on line a . The effect of the propagation process (step 3) is to move the fault effect through a sensitized path to an output of the circuit.

One of the classical methods for detecting stuck-at faults is the D-algorithm [10] which employs the path sensitization technique. The set of five elements $\{0, 1, X, D, \bar{D}\}$ for representing signals is used to facilitate the path sensitization process. X means unknown. D represents a signal which has the value 1 in a normal circuit and 0 in a faulty circuit. \bar{D} is the complement of D . The D-algorithm consists of three parts: fault excitation and forward implication, D-propagation, backward justification. On the first step the minimal input conditions are selected in order to produce an error signal (\bar{D} or D) on the output (faulty node) of the logic element. The forward implication process is performed in order to determine the outputs of those gates whose inputs are specified. The goal of the D-propagation step is to propagate the fault effect to primary outputs by means of assigning logical values to corresponding internal lines and primary inputs. In backward justification, node values are justified from primary inputs. If there is a conflict in one of the nodes the backwards consideration from the conflict node to the primary inputs is reiterated until the fault effect (\bar{D} or D) reaches at least one of the primary outputs.

Not all the stuck-at faults of the CUT can be detected by path sensitization algorithms. Hardware redundancy is the reason why these faults cannot be detected. For example, the stuck-at-1 fault on node c of the circuit shown in Figure 2.4 is undetectable since there is no sensitization path from the fault site to the output of the CUT. It is easy to ensure that while the stuck-at-1 fault is present on node c the faulty circuit produces the correct responses. Clearly, the combinational circuit shown in Figure 2.4 produces the following Boolean function: $\overline{a \cdot \bar{b}} + b$. This function is redundant and equivalent to $\overline{a + \bar{b}}$ which is not redundant.

Although path sensitization techniques formalize the test derivation procedure, they can no longer be used in testing VLSI circuits due to drastically increasing test generation time.

2.3.2 Response evaluation techniques

The main goal for response evaluation is to detect any wrong response. There are two basic approaches for achieving this goal. The first approach uses a good response generator and the second one is based on principles of compact testing techniques.

In good response generation techniques the major problem is to choose a method of obtaining a good response for the CUT. Any faulty response can be detected by comparing good responses with responses produced on the outputs of the CUT. In the stored response testing technique (Figure 2.5) all good responses are stored in a ROM. After applying each test pattern to the CUT the actual response is compared with the good one. If they are different the comparator will activate an error signal at its output. Good responses can easily be obtained by means of software-simulation of the VLSI circuit as a part of the design verification stage [9].

Figure 2.6 shows the flow diagram for the comparison testing technique. In order to detect any faulty response test patterns are applied to the inputs of the CUT and a golden unit simultaneously and the responses of both units are compared by the comparator.

In comparison with stored response testing, comparison testing has some advantages:

1) it allows the testing of VLSI circuits over a large range of speeds and electrical parameters because the golden unit and the CUT are operated under the same conditions;

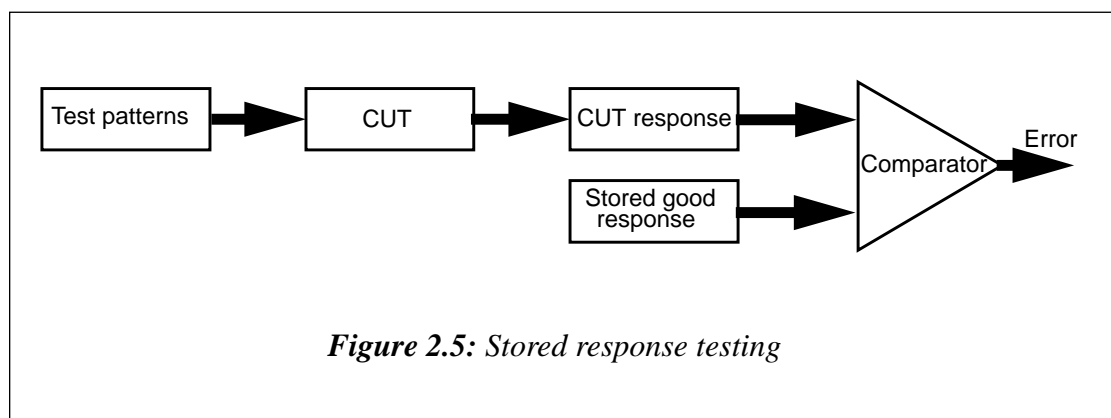

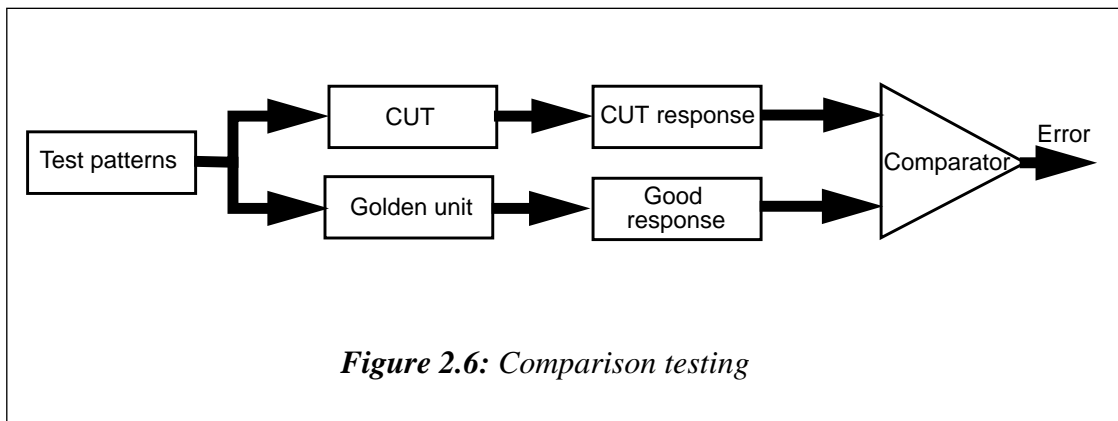

2) a change in the test sequence does not require any change in the test process.

On the other hand, the stored response testing technique needs to store good responses (the results of simulation) only once before testing whereas the quality of comparison testing depends on the quality of the golden unit.

The main drawback of the response evaluation techniques is the necessity to operate with a large amount of response data during the testing of VLSI circuits. In order to simplify the problem of storing and analysing test responses the compact testing methods have been devised [14]. The general idea of compact testing is to compress the response data into a compact form during the test. After the test is complete the response of the CUT is compared with the compressed response of the golden unit. A basic diagram of the compact testing technique is shown in Figure 2.7. However, during the compression process there is a probability that some part of the diagnostic information from the

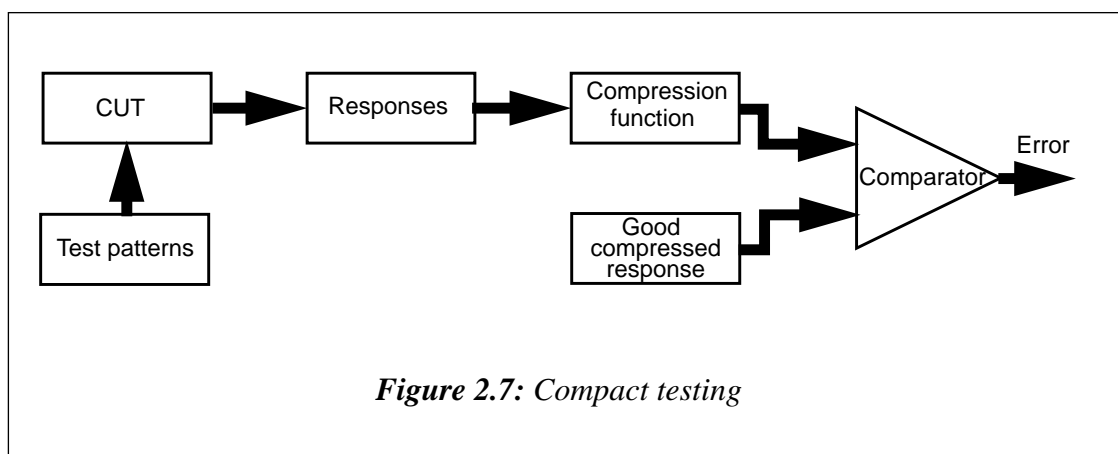

response data flow will be lost. This in turn creates the possibility of making a wrong decision about the test results. All the compact testing methods differ in the method of data compression. The most widely used compact testing methods are transition counting [14] and signature analysis [19, 26]. The transition counting method compresses the response data into the number of 0 to 1 and 1 to 0 transitions in the sequence. In the signature analysis technique the response data are compressed using a signature analyser built as a linear feedback shift register. This method will be described in more detail in Chapter 3.

Chapter 3 : Pseudo-random testing of VLSI circuits

Deterministic test generation methods for modern VLSI circuits are becoming too expensive in terms of computational time. As an alternative, random (pseudo-random) techniques for generating test sets can be used. The random (pseudo-random) testing technique consists of applying a random (pseudo-random) test sequence to a CUT and a golden unit with a consequent comparison of the two responses obtained (see Figure 2.6). The main feature of this kind of testing is that the test sequence does not depend on the specification of the CUT and can be applied to all circuits to be tested. As a result, the costs for implementing such testing are less than that of algorithmic test generation techniques.

3.1 Generating pseudo-random patterns

There are two ways to generate random test sequences. The first method lies in using random number programs to generate random tests. Knuth discussed thoroughly the properties of software random number generators [27]. The second method is more convenient for testing VLSI circuits. It uses a linear feedback shift register (LFSR) to generate random input stimuli. The standard LFSR consists of a series of D-type flip-flops without external inputs and with linear feedback provided by means of XOR gates. Such an LFSR implements the following function:

$$a(t+n-1) = \sum_{i=1}^n \alpha_i a(t+i-1), \quad (1)$$

where t is a clock number; $a(t) \in \{0, 1\}$ are the symbols of the generated sequence; $\alpha_i \in \{0, 1\}$ are constants; \sum is the operation of XORing n logical variables.

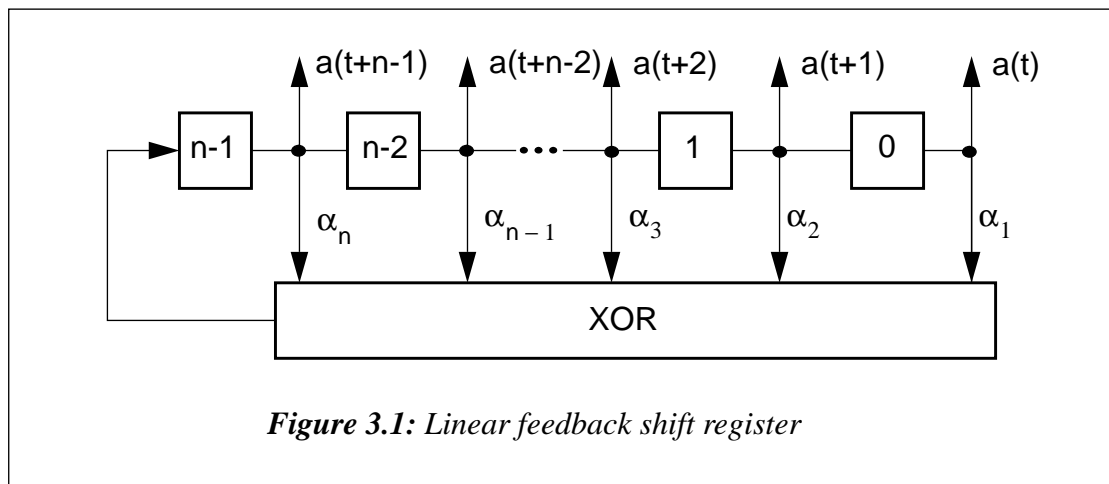
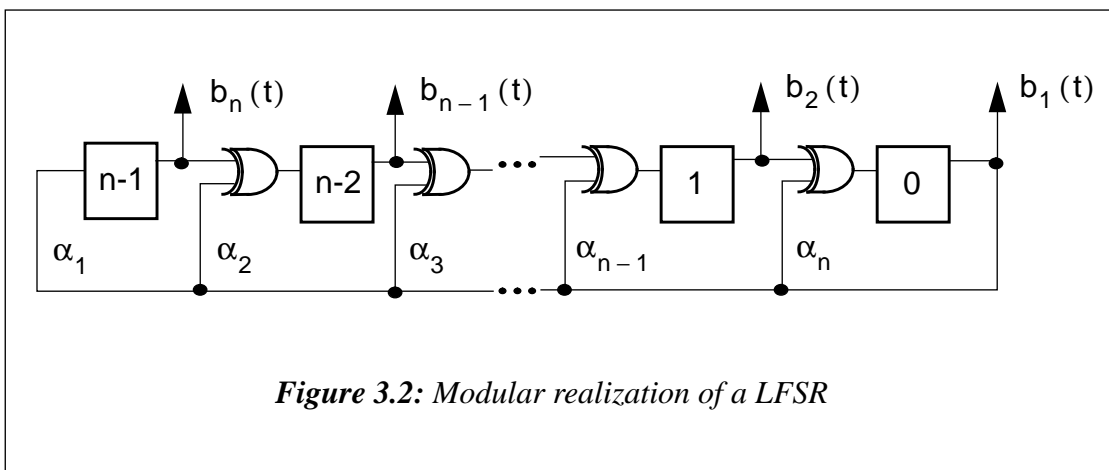
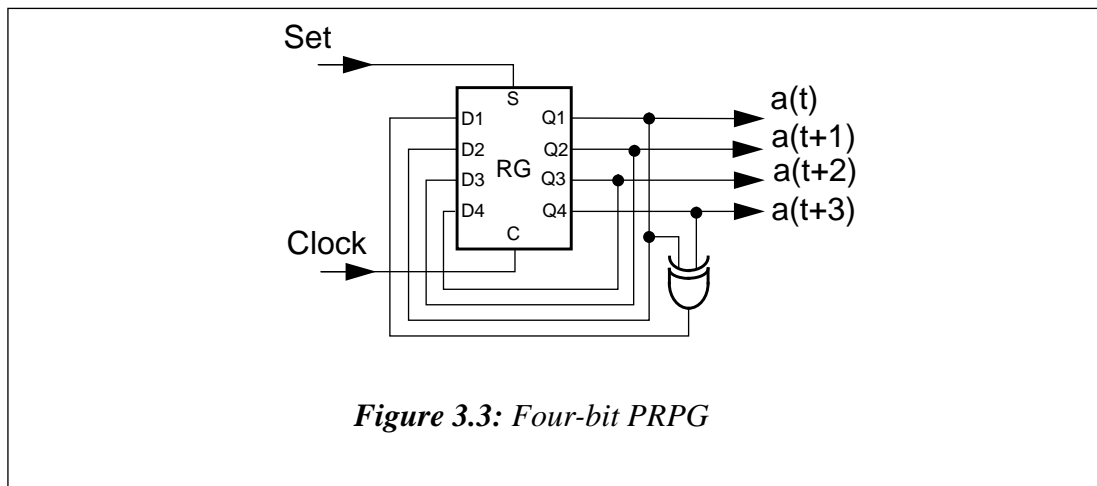

Figure 3.1 shows the general structure of an LFSR. Symbol α_i indicates the presence ($\alpha_i = 1$) or absence ($\alpha_i = 0$) of a feedback connection from the output of the i th stage to the XOR network. Sometimes the coefficients α_i are called “taps” since they determine the structure of the LFSR.

An LFSR can be realized in a modular form depicted in Figure 3.2. The modular realization of an LFSR [28] has the same number of XOR gates as the standard structure, which is defined by feedback taps. If the number of feedback signals, k , is more than 2, the modular LFSR is faster than the standard one: the former has one gate propagation delay whereas the standard LFSR has $k - 1$ gate delays per one clock.

If a homogeneous Bernoulli process [29] is used for simulating the behaviour of an LFSR such a procedure is called “random pattern generation”. As the nature of the pat-





terns generated by an LFSR is deterministic, a non-homogeneous Bernoulli process can be used for simulation. This is called pseudo-random pattern generation [24].

It is easy to show that for a certain combination of coefficients α_i , the period of the sequence, $a(t)$, generated by an LFSR will be maximal and equal to $M = 2^n - 1$. Although such a sequence can be characterized by equiprobable and randomly appearing 1s and 0s, as in a truly random sequence [30], the signals generated by an LFSR can be reproduced repeatedly after setting it into the initial state. For this reason, the sequences produced by maximal-length LFSRs are called pseudo-random sequences to distinguish them from truly random sequences. Pseudo-random sequences are more suitable for testing digital circuits than truly random ones due to the possibility of repeating them for simulation purposes.

Figure 3.3 shows a four-bit pseudo-random pattern generator (PRPG) which is realized using a four-bit register. The pseudo-random sequences of maximal period, $M = 15$, are generated on the register outputs (see Table 3.1). If the initial state of the PRPG is $(q_1, q_2, q_3, q_4) = (1, 1, 1, 1)$ then the sequence 101011001000111 is reproduced on output $a(t)$ after each 15th clock (the combination of all 0s is never produced).

The behaviour of the LFSR (Figure 3.1) can be described by means of the following matrix:

Table 3.1: State sequence for the four-bit PRPG

State	Q_1	Q_2	Q_3	Q_4	State	Q_1	Q_2	Q_3	Q_4
0	1	1	1	1	8	1	0	0	1
1	0	1	1	1	9	0	1	0	0
2	1	0	1	1	10	0	0	1	0
3	0	1	0	1	11	0	0	0	1
4	1	0	1	0	12	1	0	0	0
5	1	1	0	1	13	1	1	0	0
6	0	1	1	0	14	1	1	1	0
7	0	0	1	1	15	1	1	1	1

$$\|A\| = \begin{vmatrix} \alpha_1 & \alpha_2 & \dots & \alpha_{n-1} & \alpha_n \\ 1 & 0 & \dots & 0 & 0 \\ 0 & 1 & \dots & 0 & 0 \\ \dots & \dots & \dots & \dots & \dots \\ 0 & 0 & \dots & 1 & 0 \end{vmatrix}, \quad (2)$$

where the values of all the coefficients α_i are defined by the feedback connections of the LFSR. The elements of the first row determine the XOR operation. The other elements of matrix (2) define the shift operation. If the sequence of LFSR states is denoted by $Q = (q_1, q_2, \dots, q_n)$ then the operational sequence can be represented as

$$\begin{vmatrix} q_1(t) \\ q_2(t) \\ \dots \\ q_{n-1}(t) \\ q_n(t) \end{vmatrix} = \begin{vmatrix} \alpha_1 & \alpha_2 & \dots & \alpha_{n-1} & \alpha_n \\ 1 & 0 & \dots & 0 & 0 \\ 0 & 1 & \dots & 0 & 0 \\ \dots & \dots & \dots & \dots & \dots \\ 0 & 0 & \dots & 1 & 0 \end{vmatrix} \begin{vmatrix} q_1(t-1) \\ q_2(t-1) \\ \dots \\ q_{n-1}(t-1) \\ q_n(t-1) \end{vmatrix} \quad (3)$$

Equation (3) can be rewritten in a short form as $Q(t) = \|A\| \cdot Q(t-1)$. It is necessary to mention that time t is discrete. Multiplying the current state $Q(t)$ by matrix $\|A\|$ s

times, the LFSR state at time $(t + s)$ can be found, i.e. $Q(t + s) = \|A\|^s \cdot Q(t)$. The number M is called the period of LFSR if $Q(t) = \|A\|^M \cdot Q(t)$ or $\|A\|^M = \|E\|$, where $\|E\|$ is the identity matrix.

The cyclic properties of the LFSR are defined entirely by the derivation polynomial $\varphi(X) = X^n + \alpha_1 X^{n-1} + \alpha_2 X^{n-2} + \dots + \alpha_n$ which is the determinant of the matrix $\|A + XE\|$. For example, for the LFSR shown in Figure 3.3 the derivation polynomial is

$$\varphi(X) = \begin{vmatrix} (1+X) & 0 & 0 & 1 \\ 1 & X & 0 & 0 \\ 0 & 1 & X & 0 \\ 0 & 0 & 1 & X \end{vmatrix} = 1 + X^3 + X^4 .$$

If derivation polynomial $\varphi(X)$ of power n 1) cannot be divided into any other polynomial of power less than n ; 2) is a primitive one, i.e. it cannot be the result of the division of polynomial $X^s + 1$, where $s < M = 2^n - 1$, by any other polynomial; then the LFSR designed on the base of $\varphi(X)$ produces pseudo-random sequences of maximal period M . Thus, the main aim of designing a maximum-length PRPGs is to ensure that polynomial $\varphi(X)$ obeys the above mentioned conditions.

It is known that there are precisely $\Phi(M/n)$ different polynomials which allow the generation of maximum-length pseudo-random sequences by means of an LFSR. Function $\Phi(M)$ is the Euler function [30]. The result of $\Phi(M)$ is the number of positive integers which are less or equal to M and do not have common factors with M . The number, $\Phi(M/n)$, of polynomials of power n grows rapidly with increasing n , therefore, the number of LFSRs of maximum length becomes very large. For instance, for $n = 8$ $\Phi(M/n)$ equals 16, but if $n = 16$ the number of all possible polynomials of maximum-length LFSRs is 2048. A polynomial with a minimal number of non-zero coefficients α_i can be found from the set of polynomials of power n which obey to the conditions of producing maximum-length pseudo-random sequences. This polynomial corresponds to the simplest realization of an LFSR since the feedback network of such an LFSR has the minimal number of XOR gates. Table 3.2 contains some examples of

primitive polynomials which determine the minimal realizations of maximum-length LFSRs for different n from 1 to 33. Tables of primitive polynomials can be found in [30].

Table 3.2: Primitive polynomials for different n from 1 to 33

n	$\varphi(X)$	n	$\varphi(X)$
1, 2, 3, 4, 6, 7, 15, 22	$1 + X + X^n$	13	$1 + X + X^3 + X^4 + X^n$
5, 11, 21, 29	$1 + X^2 + X^n$	14, 16	$1 + X^3 + X^4 + X^5 + X^n$
10, 17, 20, 25, 28, 31	$1 + X^3 + X^n$	19, 27	$1 + X + X^2 + X^5 + X^n$
9	$1 + X^4 + X^n$	24	$1 + X + X^2 + X^7 + X^n$
23	$1 + X^5 + X^n$	26	$1 + X + X^2 + X^6 + X^n$
18	$1 + X^7 + X^n$	30	$1 + X + X^2 + X^{23} + X^n$
8	$1 + X^2 + X^3 + X^4 + X^n$	32	$1 + X + X^2 + X^{22} + X^n$
12	$1 + X + X^4 + X^6 + X^n$	33	$1 + X^{13} + X^n$

Let $\{a_k\} = a_0, a_1, a_2, \dots, a_{M-1}$ be a pseudo-random binary sequence, where $M = 2^n - 1$ is the period of a maximum-length n -stage LFSR. Consider the basic properties of maximal-length pseudo-random sequences:

- A pseudo-random sequence has exactly 2^{n-1} ones and $(2^{n-1} - 1)$ zeros. The probability of a one (zero) on the outputs of the LFSR, p (q), can be estimated as follows

$$p = 2^{n-1} / (2^n - 1) = 0.5 + 1 / (2^{n+1} - 2)$$

$$q = (2^{n-1} - 1) / (2^n - 1) = 0.5 - 1 / (2^{n+1} - 2)$$
 . If n is quite large then the values of p and q are very close to 0.5 as in a truly random sequence.
- For a certain polynomial $\varphi(X)$ there are M different pseudo-random sequences which can be obtained from $\{a_k\}$ by cyclicly shifting it to s , $1 \leq s < M$, positions.

- In sequence $\{a_k\}$ there is only one combination of n 1s and $(n - 1)$ consecutive 0s. For $1 \leq s \leq n - 1$ there are 2^{n-s-1} runs of a combination of s consecutive 1s and s consecutive 0s. For instance, there are 4 runs of such combinations as 01 or 10 ($s = 1$) in the pseudo-random sequence generated by the 4-stage LFSR shown in Figure 3.3.
- For each integer s , $1 \leq s \leq M - 1$, there is an integer r , $1 \leq r \leq M - 1$, such that $\{a_k\} \oplus \{a_{k-s}\} = \{a_{k-r}\}$. In other words, the result of the sum of a pseudo-random sequence and its shifted version is another shifted version of the same sequence. This autocorrelation property of maximal-length pseudo-random sequences is similar to that of truly random sequences.
- Each maximal-length LFSR sequence ($n > 4$) is associated with another sequence, the reverse sequence, which consists of the symbols of the original sequence but in reverse order. The specification for the LFSR corresponding to the reverse sequence is obtained by replacing each entry i in the original specification by $n - i$. For example, for the LFSR (Figure 3.3) with derivation polynomial $\phi(X) = 1 + X + X^4$ there is another polynomial $\phi(X) = 1 + X^3 + X^4$ which determines the structure of the LFSR whose output sequence is the reverse sequence.

3.2 Exhaustive and pseudo-exhaustive testing of VLSI circuits

It is well known that for 100% testing of combinational circuits all binary input combinations should be applied to its input. This approach is called exhaustive testing. A binary counter can be used to generate all combinations of binary symbols. A modified version of a maximal-length LFSR can also be used for exhaustive testing [23]. This LFSR is forced to go through all states including the all-0 state. This can be done with the help of the extra NOR gate incorporated into the LFSR structure as shown in Figure 3.4. As a result, the LFSR cycles through all its original states plus the all-0 state which is forced by the NOR gate in the state 0001. After the all-0 state the LFSR goes to the state 1000 and then the sequence proceeds as before (see Table 3.1). The main short-

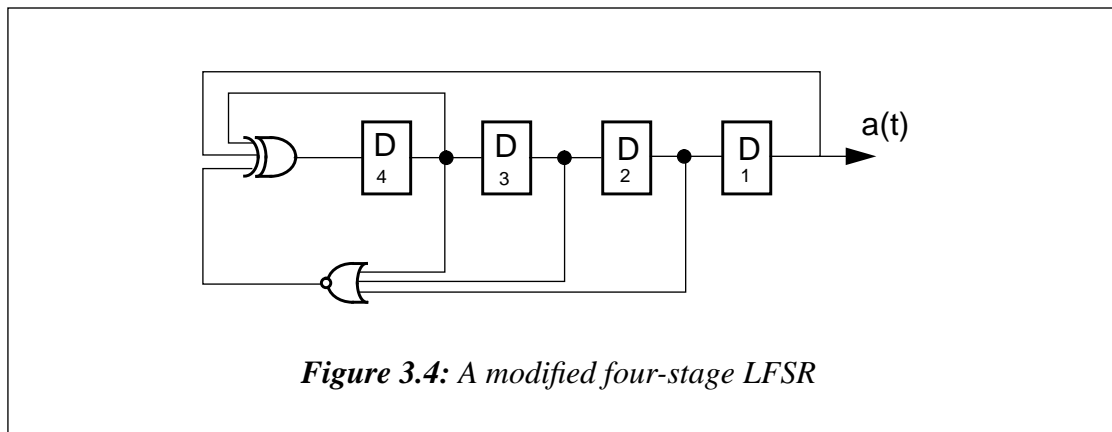

coming of the exhaustive testing technique is that it requires test sequences which are too long when testing combinational circuits with large numbers of inputs. To reduce the exhaustive test lengths analysis of the topology of the CUT is necessary.

It was shown by E. J. McCluskey [31] that the vast majority of practical multi-output combinational networks can be exhaustively tested by applying exhaustive tests only to parts of them. This testing technique is called pseudo-exhaustive or verification testing. The main point of this approach is to find a subset of inputs which determines logical values on each output of the circuit to be tested. All possible vectors are applied to the subsets of the CUT inputs during pseudo-exhaustive testing. As a result, all subfunctions of the circuit and, therefore, the entire circuit are exhaustively tested. However, when an output of the CUT depends on all the inputs the verification testing technique cannot make exhaustive testing shorter than when all binary combinations are applied to all inputs of the circuit. E. J. McCluskey also proposed the division of the circuit into segments and partitions, each tested exhaustively [23]. The major requirement of this approach is that all subcircuits' inputs must be controllable at the primary inputs and all subcircuits' outputs must be observable at the primary outputs of the circuit. To achieve this goal two ways of partitioning the entire circuit were proposed. According to the first way (hardware partitioning), the embedded inputs and outputs of each subcircuit under test are accessed through multiplexers incorporated into the circuit. The hardware partitioning approach can be used for most combinational networks but it introduces some hardware redundancy which, in turn, can reduce the operating speed of the circuit. The

second method (sensitized partitioning) applies appropriate input patterns to the primary inputs of the circuit to partition it and isolate subcircuits not to be tested.

3.3 Signature analysis

The first practical realization of the signature analysis technique, as a method of detecting errors in output data streams produced by hardware designs, was pioneered by Hewlett Packard Ltd. [26]. Signature analysis uses a special technique of data compression and stores the responses obtained from the CUT in compact forms called signatures. A circuit used for implementing the data compression technique is called a signature analyser. Figure 3.5 represents the general structure of a signature analyser. This structure includes an n -bit shift register and a feedback XOR gate fed by 1) the shift register outputs defined by coefficients of the appropriate derivation polynomial; 2) an input data stream from the outputs of the CUT. The initial state of the signature analyser is the all-0 state. After the data stream, $y(t)$, has been clocked through, the content (signature) of the shift register can be calculated as shown below:

$$a_i(0) = 0, 1 \leq i \leq n,$$

$$a_1(t) = y(t) \oplus \sum_{i=1}^n \alpha_i a_i(t-1), \quad (4)$$

$$a_j(t) = a_{j-1}(t-1), 2 \leq j \leq n, 1 \leq t \leq 2^n - 1.$$

It is clear from (4) that if the input data stream is all 0's then the signature produced by the signature analyser is one of the states of the maximal-length LFSR.

From a mathematical point of view the process of calculating signatures can be described as a procedure for dividing an input data stream represented in a polynomial form into the primitive polynomial of the LFSR. Any k -bit sequence can be written as polynomial $\psi(X)$ of power $k-1$. For example, the 5-bit sequence 10011 can be written as $\psi(X) = X^4 + X + 1$. The result of dividing $\psi(X)$ into primitive polynomial $\phi(X)$ can be described by the following equation $\psi(X) = z(X)\phi(X) \oplus s(X)$, where $s(X)$

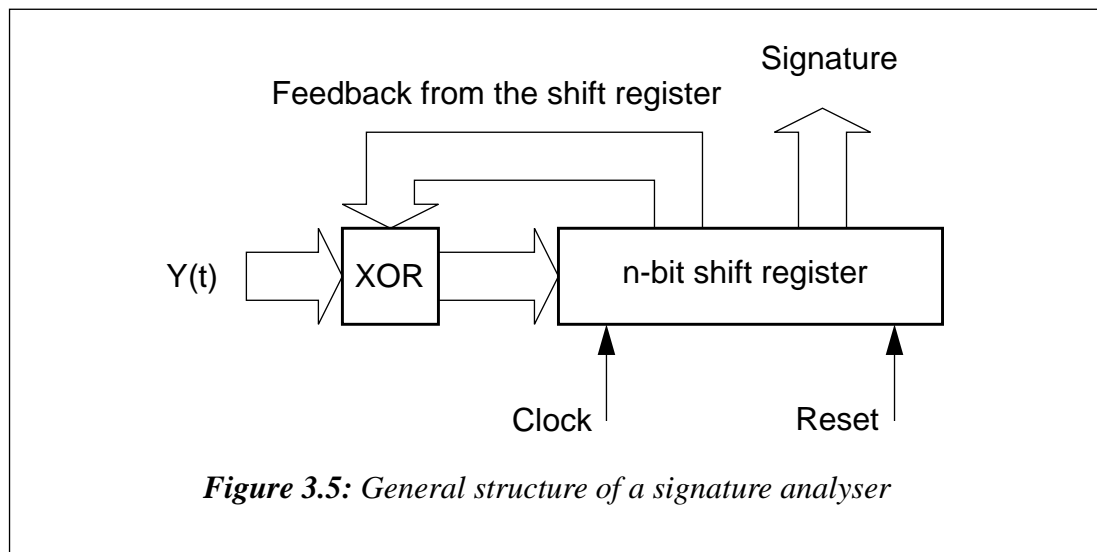

is the residue of the division. In other words, the residue of dividing the input polynomial describing the data flow into the primitive polynomial is the signature.

In signature analysis testing the inputs of the CUT are supplied with tests produced by the test generator. Unique signatures are calculated at each internal node and primary output of the circuit tested. The obtained signatures are stored for comparison with good signatures obtained at the same nodes from the golden unit or from simulation of the CUT. If any differences between the two signatures for each node are found the CUT works incorrectly. By comparing signatures from the primary outputs to the primary inputs the fault site can be discovered.

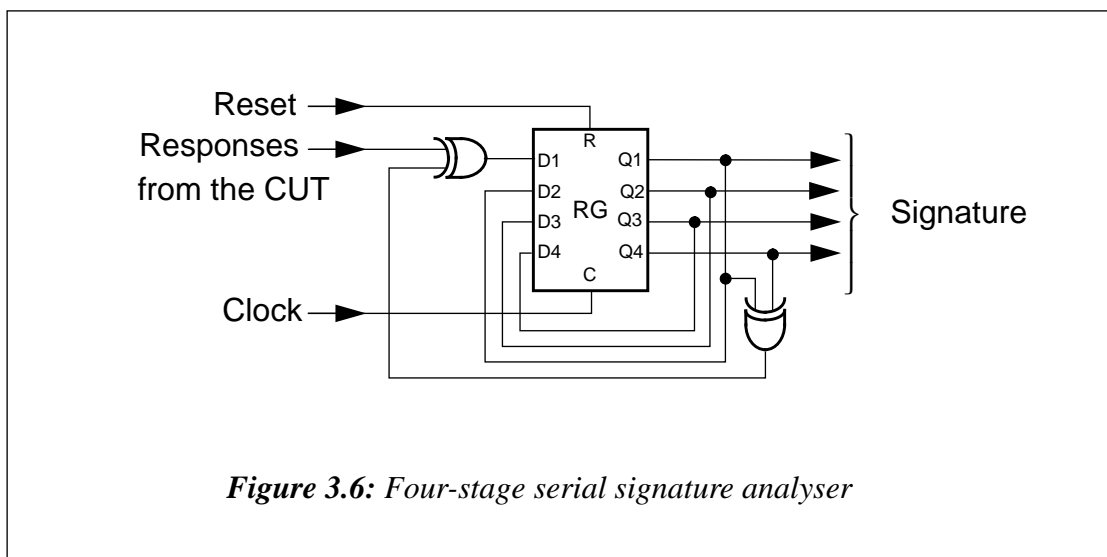

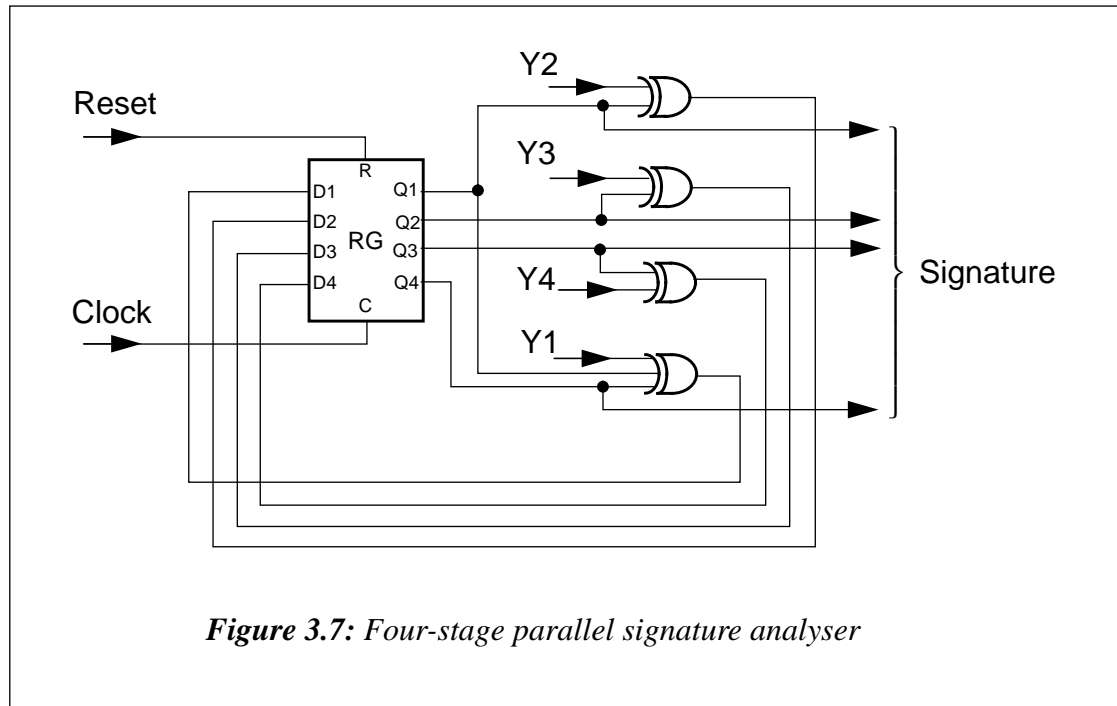

In practice, two basic kinds of signature analysers are used: serial and parallel signature analysers [28]. A four-stage serial signature analyser and four-stage parallel signature analyser are shown in Figure 3.6 and Figure 3.7 respectively. A serial signature analyser treats only one response bit at every clock whereas a parallel signature analyser compacts responses from the outputs of multiple networks under test.

Let us evaluate the probability that an error will not be detected by a signature analyser. Assume that an input sequence of a given length, say m , can be good or faulty at random. There are 2^n possible signatures which are produced by an n -bit signature analyser. From the set of all possible input sequences of length m there are 2^{n-m} sequences which map into one signature. Thus, there are $2^{n-m} - 1$ error sequences which are undetectable because they leave the same residue as the correct sequence. This causes fault masking errors in a signature analyser. The probability of a signature analyser failing to detect an error can be evaluated by dividing all error sequences which map into the same signature by the total number of error sequences, i.e. $P = (2^{m-n} - 1) / (2^m - 1)$. For long input sequences, when m is large enough, $P \approx 1/2^n$.

In summary, a signature analyser based on an LFSR can detect all errors in data streams of n or fewer bits, because the entire sequence will remain in the shift register. For long sequences, whose lengths are more than the LFSR length, the probability of fault masking errors in a signature analyser depends on the LFSR length. For the 16-bit signature analyser used by Hewlett Packard $P = 1.5 \times 10^{-5}$. This confirms the high quality of the signature analysis technique.

Chapter 4 : Design for testability of VLSI circuits

4.1 What is design for testability?

It is known that the major parts of testing costs are the cost of test pattern generation and the cost of test application. Testability is a measure of how easily a VLSI circuit can be tested to ensure that it performs its intended function. A circuit which can be tested with less time and effort possesses a greater degree of testability. A circuit which has undetectable faults is untestable and possesses a zero level of testability. Between these two extremes there are VLSI circuits which have to be tested for long times and/or require expensive test equipment. Therefore, design for testability (DFT) can be defined as a design philosophy that leads to decreasing the cost of testing digital circuits and to increasing the fault coverage or fault isolation.

There are two key concepts in DFT techniques: controllability and observability [32-35]. Controllability refers to the ease of producing test patterns to the inputs of the sub-circuit via the primary inputs of the CUT. Observability refers to the ease with which the responses of the subcircuit can be determined via the primary outputs of the CUT. The degree of controllability of the circuit can be increased by means of incorporating in it some additional logic elements and control terminals. The easiest way to increase observability is to add some extra output terminals into the CUT.

The procedure for designing for testability assumes that modifications of the circuit are possible to ease the generation and application of test vectors to the circuit to be tested. To improve testability three groups of DFT techniques have been used: an ad hoc strategy, structured approaches and built-in self-test techniques [33]. There are several basic criteria which must be taken into account when choosing the most suitable DFT method for designing a VLSI circuit. These are as follows:

- impact on the original VLSI design: the increase in silicon area; effects on performance; the testability of the extra logic;
- the ease of implementation of the technique chosen;
- the effects on test pattern generation: reduction in computational time; improved fault coverage; reduction in engineering effort;
- additional requirements for automatic test generation tools.

4.2 Ad-hoc techniques

The ad-hoc strategy is used to help designers of VLSI circuits to alleviate testing problems. Test engineers, using their experience, have developed a number of recommendations for enhancing the testability of VLSI circuits. R. G. Bennetts described some practical guidelines for designing testable circuits [32]. All these recommendations can be divided into two groups: the guidelines which 1) make test pattern generation easier; 2) simplify test application and fault isolation. Consider some ad-hoc rules for improving VLSI design testability:

It is known that primary access to subcircuits of a VLSI design is extremely limited. In this case the use of multiplexers and demultiplexers can improve controllability and observability characteristics of the VLSI circuit as shown in Figure 4.1. Demultiplexers

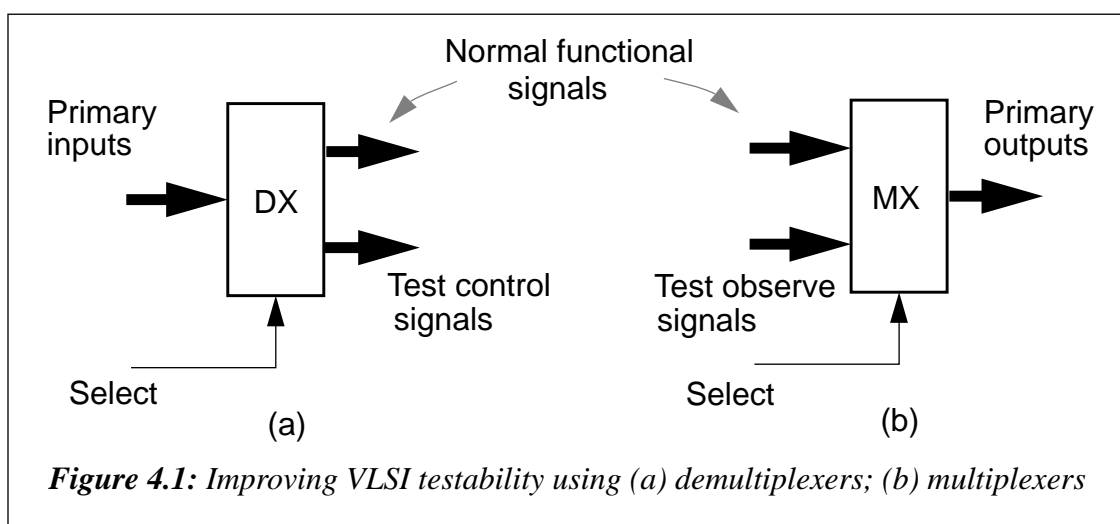

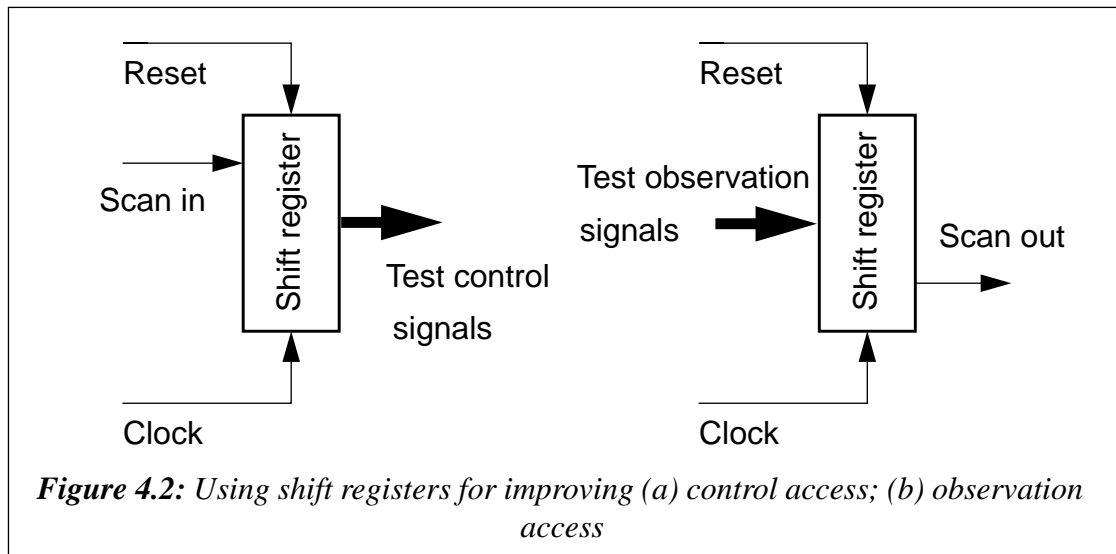

and multiplexers incorporated into the VLSI circuit allow the test engineer to change the directions of data stream manipulations inside the circuit which are dependent on the chosen mode of operation (normal or test mode). The major penalties of such an approach are hardware redundancy and additional propagation delays included into the VLSI circuit.

Shift registers can be used to make internal nodes of the VLSI circuit more accessible either for controllability or observability as shown in Figure 4.2. A serial-in, parallel-out shift register is used to set the circuit into a predefined state (see Figure 4.2(a)). Figure 4.2 (b) shows a parallel-in, serial-out shift register which is used to store test information from internal nodes and to scan it out to a primary output of the VLSI circuit.

The addition of extra gates to block signal paths can be used to partition a VLSI design into smaller subcircuits, provide facilities to break feedback paths, break up long counter chains and provide initialisation of stored-state devices for simplifying test generation. This technique has been described in detail [23, 32].

Ad-hoc techniques can be applicable to almost any VLSI design and do not impose severe restrictions upon the designer. However, these methods are not easily automated, and test generation and fault simulation for ad-hoc approaches are not usually as simple as they would be for structured techniques. The reason for using this very inadequate

DFT strategy is due firstly to the fact that the designer does not have the expertise required for testing and secondly that no effective analysis tools are available to make good this shortcoming.

4.3 Structured approaches

Although automatic test pattern generators and ad-hoc techniques ease some of the test problems they cannot ensure the desired degree of controllability and observability at the structural level for such complicated systems as VLSI circuits. In the mid to late 1970s a number of structural DFT approaches were proposed. Most of these structured approaches rely on the concept that, if one can control and observe the latch variables within a sequential circuit, then the test generation problem can be reduced to the testing of just the combinational logic. The basic structure of the Huffman model for a sequential network is shown in Figure 4.3. This model includes a number of memory elements, ME_i ($1 \leq i \leq n$), separated from the combinational logic, CL. The combinational logic is fed by the primary inputs and the outputs of memory elements placed in the feedback loops. If all the memory elements could be treated by a straightforward mechanism to control and observe their states, then the test generation and fault simulation need to be done only for the combinational logic rather than for the much more difficult case of the sequential circuit. As a result of considerable research into structured DFT techniques,

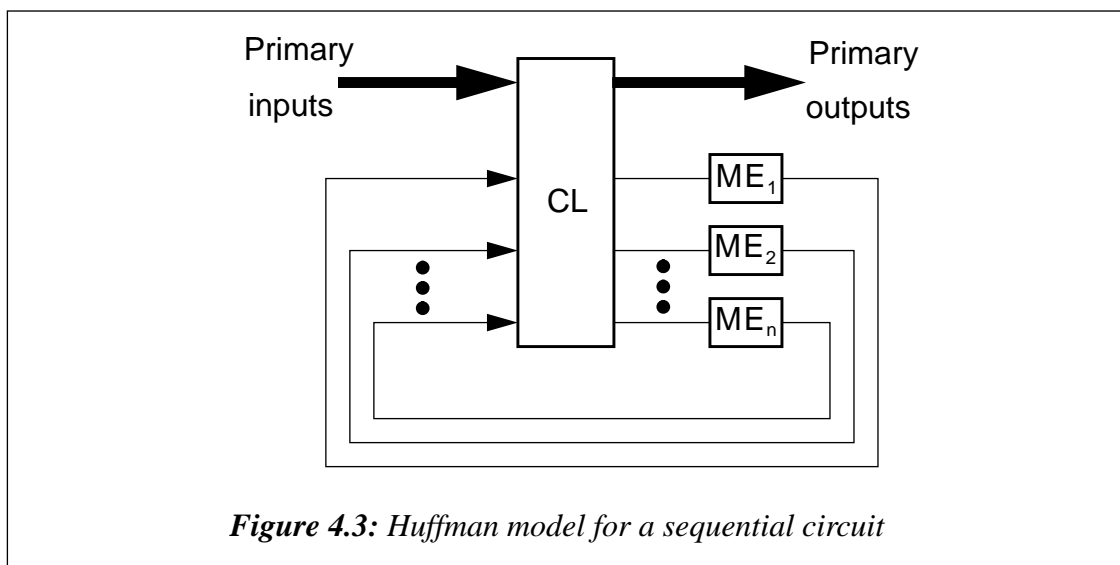

four main formal methods have evolved: scan path [28,34], level-sensitive scan design [8,13,32], scan/set [9,14] and random access scan [33].

4.3.1 Scan path

The scan path approach assumes that during the test all the memory elements of the sequential circuit are configured into a long shift register (see Figure 4.4) called the scan path. All the memory elements of the circuit can be controlled and observed by means of shifting in and shifting out test data along the path. During normal operation all the storage elements are reconfigured in the way shown in Figure 4.3. The selection of the input source for the storage elements can be achieved using multiplexed data flip-flops [28] or two-port flip-flops with two data inputs and two clocks [9].

A scan path technique can be used to partition a VLSI structure into a number of less complex subcircuits by organizing the scan path to pass through a number of combinational networks. The sequential depth of such a circuit is much less than the depth of the original one which alleviates the test problem considerably. To test the scan path itself, flush and shift tests are applied. The flush test consists of all zeros and all ones. The shift test exercises the memory elements of the scan path through all of their possible combinations of initial and next states.

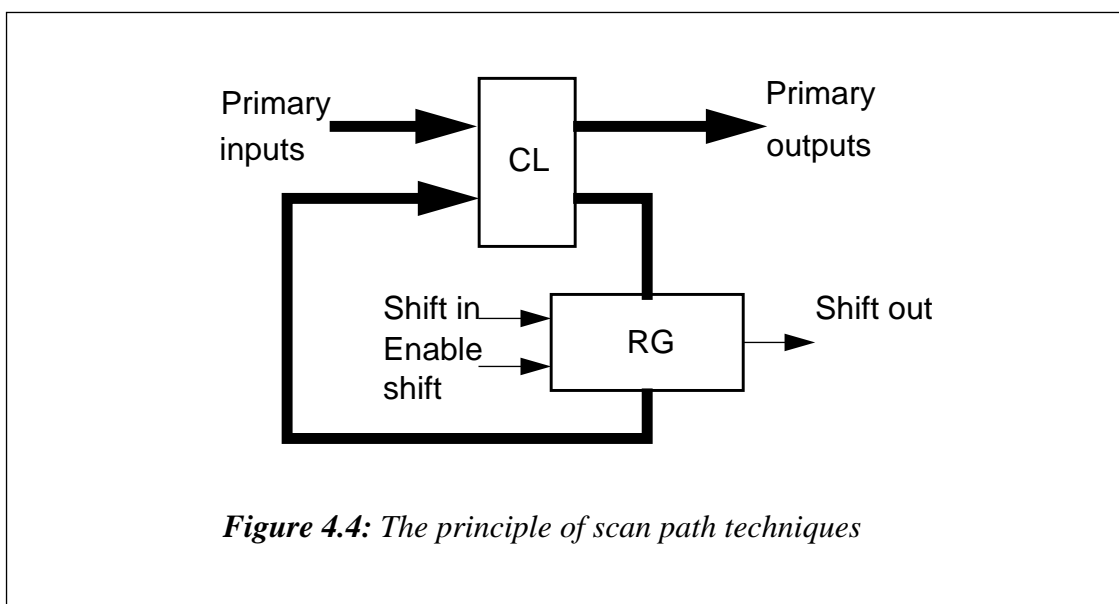

Figure 4.4: The principle of scan path techniques

4.3.2 Level-sensitive scan design

Level-sensitive scan design (LSSD) is based on two main concepts: level sensitivity, and a scan path. The first assumes that: 1) all changes in the circuit are controlled by the level of a clock signal; 2) the steady state response of the sequential circuit to an input state change is independent of the rise and fall times and propagation delays of signals within the circuit. The second concept of LSSD technique assumes that the circuit must incorporate a scan path.

Shift register latches (SRL) are used to implement all memory elements in LSSD circuits. Figure 4.5 shows the symbolic representation of an SRL and its implementation in NAND gates. In the normal mode of operation clock C3 is not activated and clock C1 is used to write data to latch L1. Output data can be taken from L1 or, if clock C2 is used, from L2. In the test operation mode non-overlapping clocks C3 and C2 are used to shift data from output L2 of the previous SRL into latch L1 (clock C3) with consequent copying of the data from output L1 into latch L2 (clock C2).

The basic LSSD configuration is illustrated in Figure 4.6. In this structure the pair of two non-overlapping clocks C1 and C2 are used to store the system data from the combinational logic, CL, in the SRLs (normal operation mode). In the test mode of operation two sequences of clocks C3 and C2 are applied to control and observe the states of all the SRLs by means of transferring test data through the scan path (dotted line). Note that both the L1 and L2 latches participate in the system function and during the test.

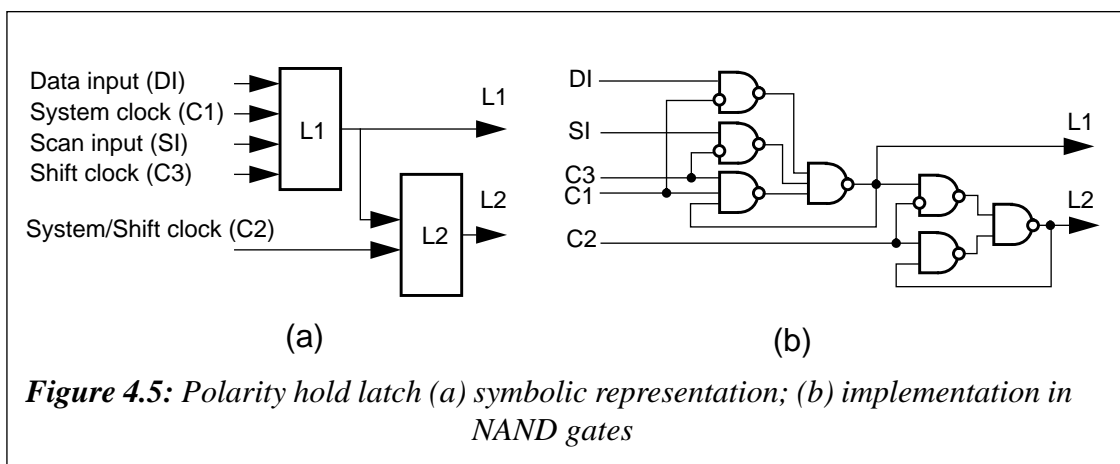

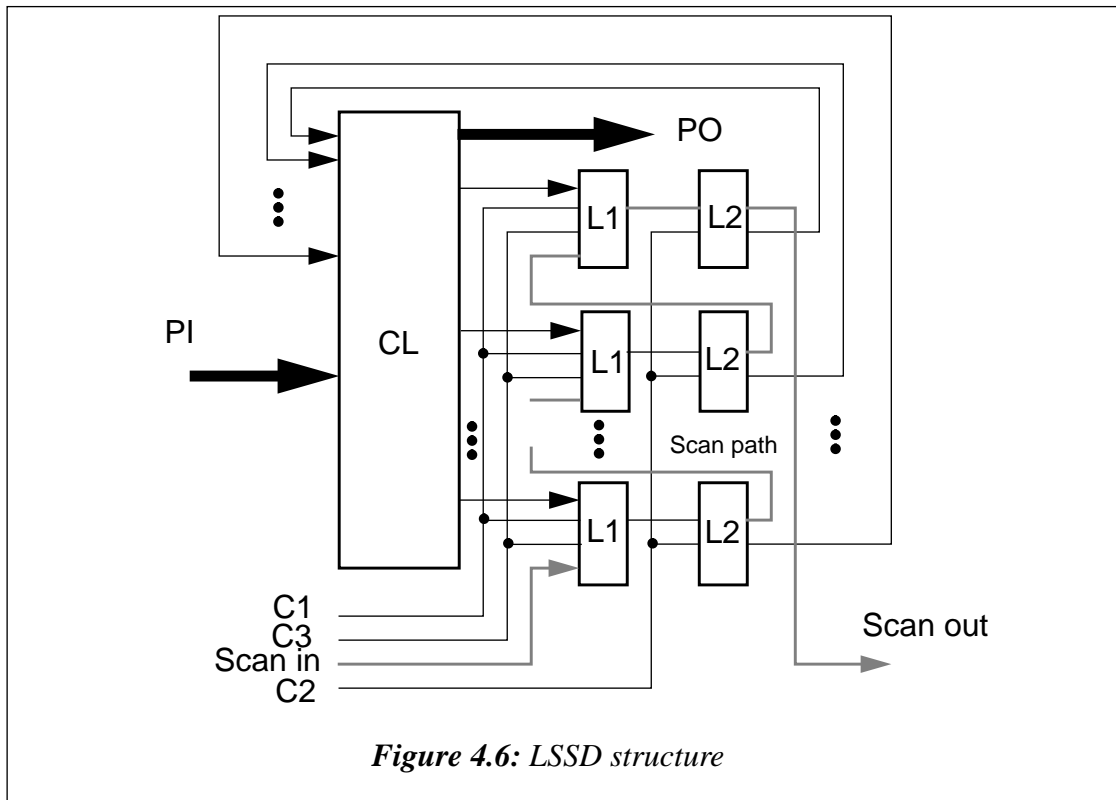

The basic algorithm for testing with the LSSD structure shown in Figure 4.6 can be written as follows:

- Verify the operation of all the SRLs by applying flush and shift tests.
- Load a test into the SRLs. The test is loaded from the scan-in port of the circuit and shifted in serially by means of clocks C3 and C2 alternatively activated.
- Generate a test pattern on the primary inputs, PI, of the circuit and turn clock C1 on and off. As a result, the response of the combinational network is stored in the L1 latches.
- Pulse the system clock C2 to rewrite the contents of the L1 latches into the L2 latches.
- Pulse two sequences of clocks C3 and C2 to scan out the contents of the SRLs. Meanwhile a new test pattern can be loaded into the SRLs.

The test procedure described above is continued until the combinational logic has been tested. The responses of the circuit are observed at the primary outputs, PO, and the scan-out port. The LSSD technique imposes on designers special design rules [32]. The incorporation of SRLs used in accordance with these rules ensures that the design will be testable. Test generation can also be fully automatic since the tests must be produced just for the combinational part of the LSSD circuit. Fault simulation is simplified greatly as a result of the elimination of hazards and races inside the network. These advantages must be balanced against: the increased silicon area of the chip (from 4% to 22%) [13]; additional delays caused by the use of SRLs; restrictions in design freedom; the need to use complex CAD design rule checkers.

4.3.3 Scan/set technique

The scan/set technique uses a shift register built by using memory elements, ME_i , which are not involved in system calculations as shown in Figure 4.7. The only function of the shift register is to shift data in and out of the circuit. Since the internal storage elements are neither controllable nor observable, this DFT approach does not separate system storage elements from the combinational circuit during the test. However, the scan/set technique allows the checking of the internal variables of the circuit during its normal functioning. This is possible because the scan path is completely separate from the system and they are controlled by independent clocks. The major advantages of the scan/set technique are: tests do not have to be conducted in a separate operation mode; the scan/set system is tested while it operates at its normal speed, so that some dynamic param-

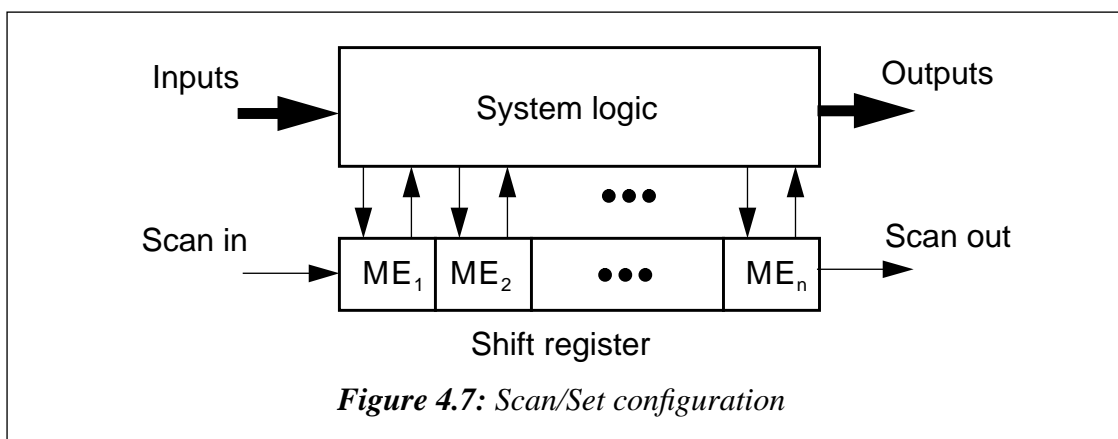

ters of the circuit can be obtained. The internal nodes of the circuit which are to be connected to the shift register are derived from the results of testability analysis programs [14,28].

4.3.4 Random access scan

The random access scan approach treats each of the latches as a bit of memory as illustrated in Figure 4.8. Each element has its own unique address in the addressable space of the whole memory. There is one common port from which data are loaded into the latch. The content of each latch is observable for inspection at one output. As a result, the random access scan structure reduces the test generation problem to producing tests only for the combinational logic, CL.

During the test operation mode in random access scan only one latch is activated at a time to control the internal state of the latch or observe its content. This, in turn, makes the test procedure slower in comparison to the use of a shift register. Other disadvantages of the random access scan approach are that: 1) it requires high overheads in terms of additional logic and input/output pins needed to implement the RAM; 2) some constraints are imposed on the logic design (for instance, the exclusion of asynchronous latch operation) [14].

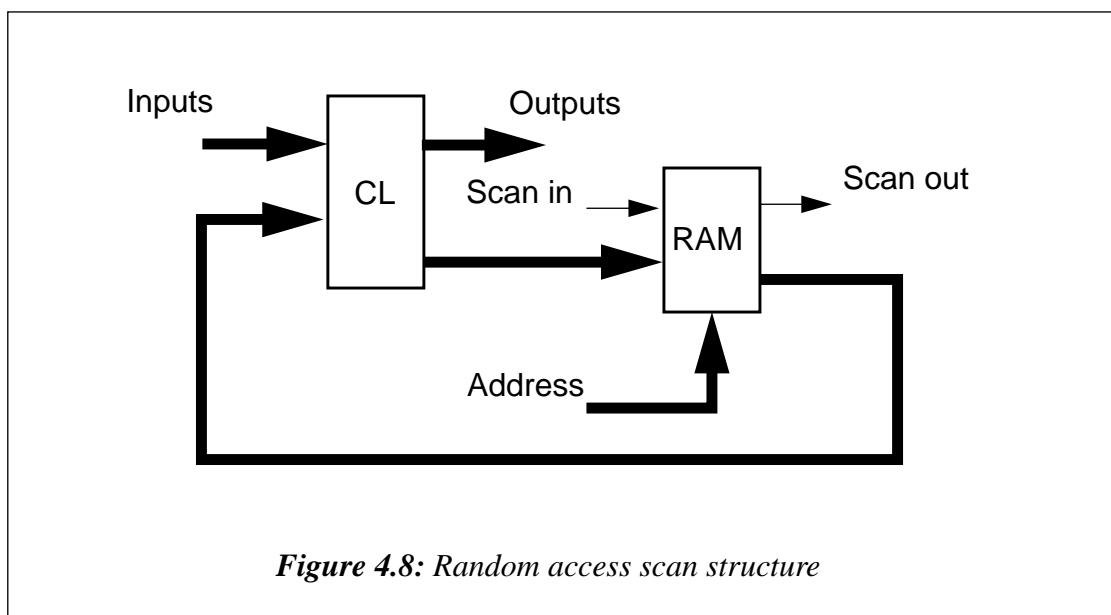

4.4 Built-in self-test

Built-in self-test (BIST) structures are chip architectures which incorporate self-test ability. A number of variations of the scan path designs have been proposed with BIST characteristics [9,14,21,23,28]. In these designs the test patterns are generated by a circuit included on the chip and the response analysis is also fulfilled by on-chip circuitry. The major factors which make BIST techniques the target of intensive research are:

- the growing volume of test data required for testing VLSI circuits and, as a result, the increasing test time;
- the high cost of test equipment;
- the need to test a VLSI circuit at its normal operation speed which is difficult to implement using multi-functional testers.

Figure 4.9 shows the taxonomy of self-test approaches. The microprocessor self-stimulated testing uses functional patterns generated by the microprocessor. These patterns are applied to the network and the responses to the tests are stored in a register within the network. Another type of self-test techniques applies random/pseudo-random patterns to the network and compresses the test results inside the chip. There are two possible realizations of such self-test approach: InSitu and ExSitu self-testing [9]. The main

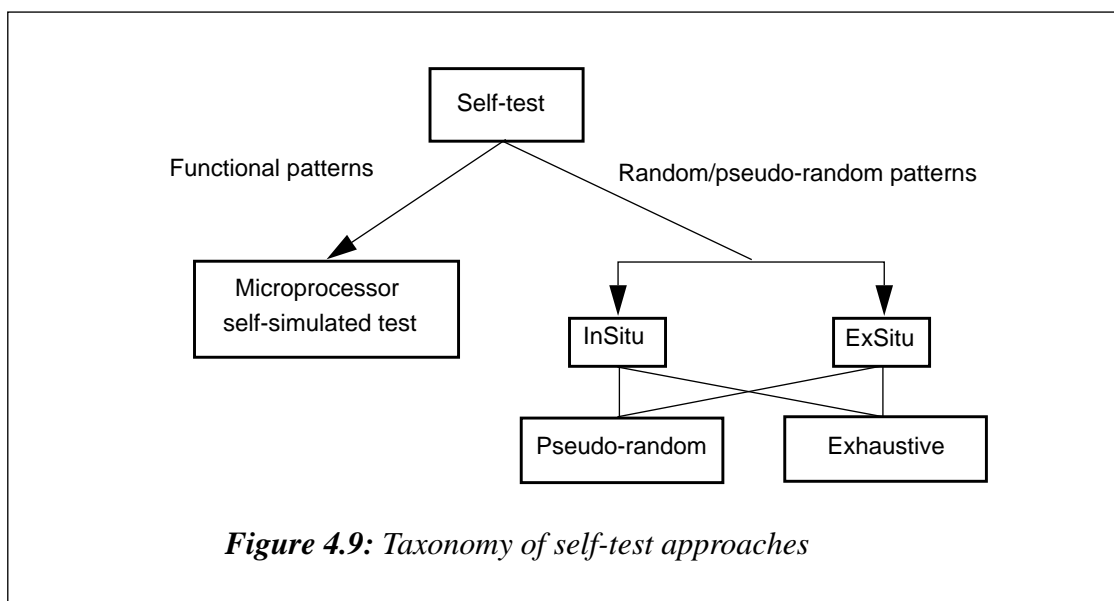

difference between these two approaches is that InSitu self-test uses system registers to generate and compact test data whereas the ExSitu structure uses registers external to the system function to generate tests and analyse the responses of the circuit.

4.4.1 InSitu self-testing

The classical examples of InSitu self-test are the built-in logic block observation technique [14] and built-in verification testing [23,31].

Built-in logic block observer

This technique is based on the use of a multi-purpose test module named a “built-in logic block observer (BILBO)” which can be reconfigured to function as a pseudo-random pattern generator or as a signature analyser within a VLSI circuit. The BILBO technique uses signature analysis in conjunction with a scan path technique. The structure of a basic 4-bit BILBO element is shown in Figure 4.10. The function of the BILBO element is controlled by lines B1 and B2. The storage elements are D-flip-flops. The inputs of the BILBO element are usually fed by the outputs of the preceding combinational circuit, the outputs are connected to the inputs of the succeeding combinational network. There are four modes which can be defined for the BILBO register as follows:

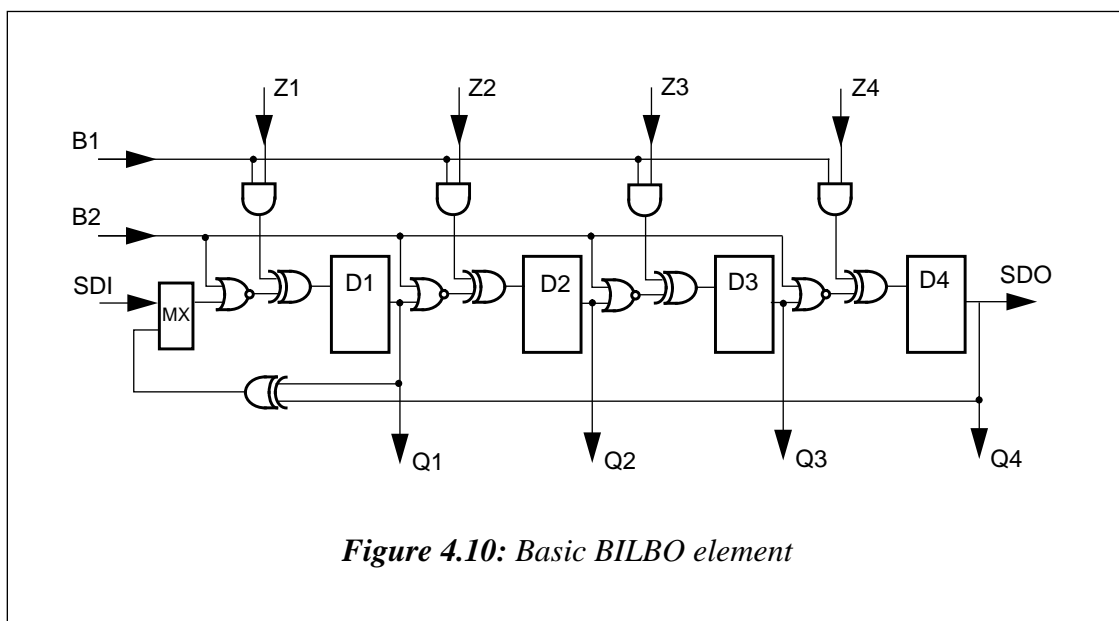
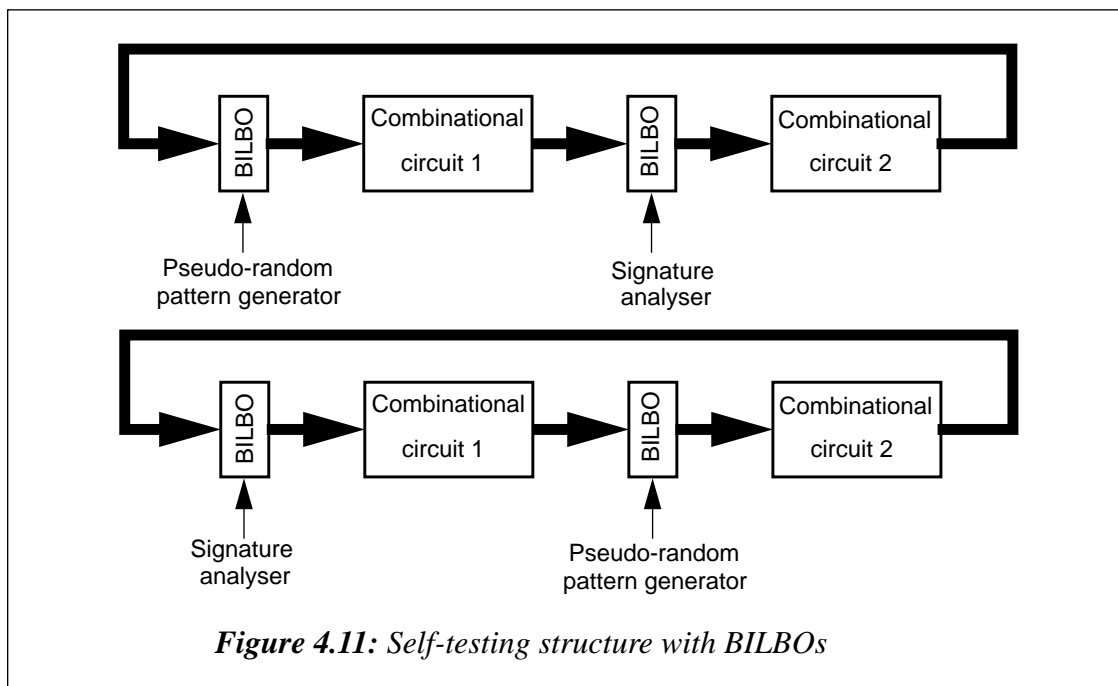

Figure 4.10: Basic BILBO element

1. $B1=B2=1$, *System operation mode*. The BILBO is configured as a set of D flip-flops to store system states of a VLSI circuit.
2. $B1=B2=0$, *Shift register mode*. The BILBO functions as a long shift register forming a scan path.
3. $B1=1, B2=0$, *LFSR with multiple inputs*. If all the inputs of the BILBO are fixed the BILBO element shown in Figure 4.10 is configured into the 4-stage PRPG (see Figure 3.3). Otherwise the BILBO functions as the 4-bit parallel signature analyser as shown in Figure 3.7.
4. $B1=0, B2=1$, *Reset mode*. The BILBO register is reset.

Figure 4.11 shows how the BILBO technique can be used to test a VLSI circuit. Initially one BILBO register works as a PRPG to stimulate the combinational circuit to be tested. The second BILBO is used as a signature analyser to compress the responses of the circuit under test. After a certain number of clocks the BILBO register that contained the signature is reconfigured into a scan path register and the content is shifted out to compare with the signature of the golden unit. The roles of the BILBOs are reversed to test the next combinational circuit. The above method is called the simplex method of self-



test. The simplex method is more efficient for self-testing pipelined structures but it has considerable drawbacks for circuits in which the inputs to one block are formed from the outputs of many other blocks. In such cases duplex methods must be used where each functional block has its own PRPG and signature analyser.

There are some networks which are difficult to test by the BILBO technique. For example, such circuits as PLAs have a very high ratio of fan-in to logic gates. The probability of detecting some faults in PLAs can be very low during random testing which causes the test length to be prohibitively long. Therefore, in order to have this kind of circuit tested, either deterministic test patterns need to be applied or the circuit must be modified. Another problem in using the BILBO method lies in the difficulty of calculating fault free signatures and total fault coverage. The overhead for BILBO is the LSSD or scan path overhead plus at least one exclusive OR gate per stage of shift register.

Built-in verification testing

This is a technique which applies all possible patterns to the combinational part of the VLSI circuit. The main principle of verification testing is that if all possible patterns are applied and the fault mechanism does not change the combinational circuit into a sequential one, then any faults of the circuit will be detected. During verification testing every single point in the Karnaugh map is inspected. In the case when every output of a combinational logic block is not a function of all the inputs, a subset of all possible patterns can be applied to test each subfunction.

The difference between BILBO and verification testing is that the BILBO technique needs to have a tool to determine the number of random patterns required for random testing. Also this tool must indicate whether the circuit is testable with random patterns which is not an easy task [35]. During verification testing, since all possible patterns are applied to the inputs of the combinational part of the circuit, all faults which are not redundant will be detected. No special tools are required for such an approach. There is only one major restriction which is to ensure that there are no redundancies in the network under test.

4.4.2 ExSitu self-testing

ExSitu BIST structures generate pseudo-random patterns and compact the test results by means of LFSRs which are not part of the system logic as illustrated in Figure 4.12.

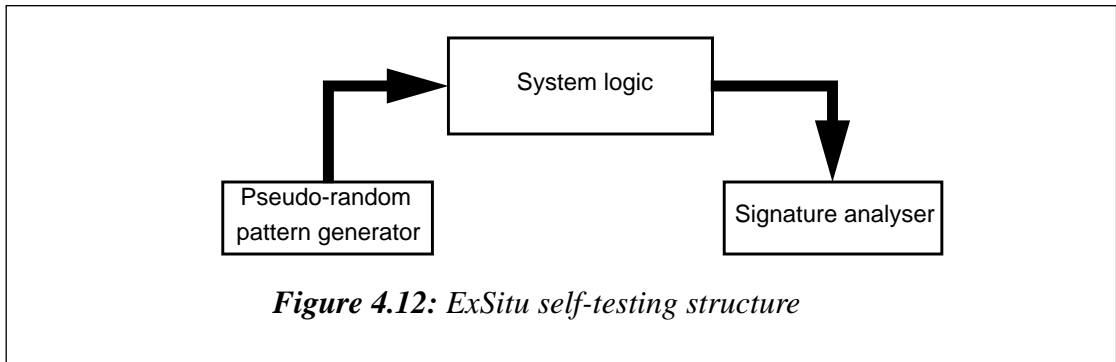

Figure 4.12: ExSitu self-testing structure

LSSD on-chip self-test

The LSSD on-chip self-test (LOCST) technique has been developed to reduce the volume of test data to be applied during the random testing of a chip [36]. The basic structure of the LOCST method is shown in Figure 4.13. The test technique is based on a scan path approach which uses LSSD latches. There is a special control circuit called the on-chip monitor, OCM, which monitors the modes of operation of the whole chip.

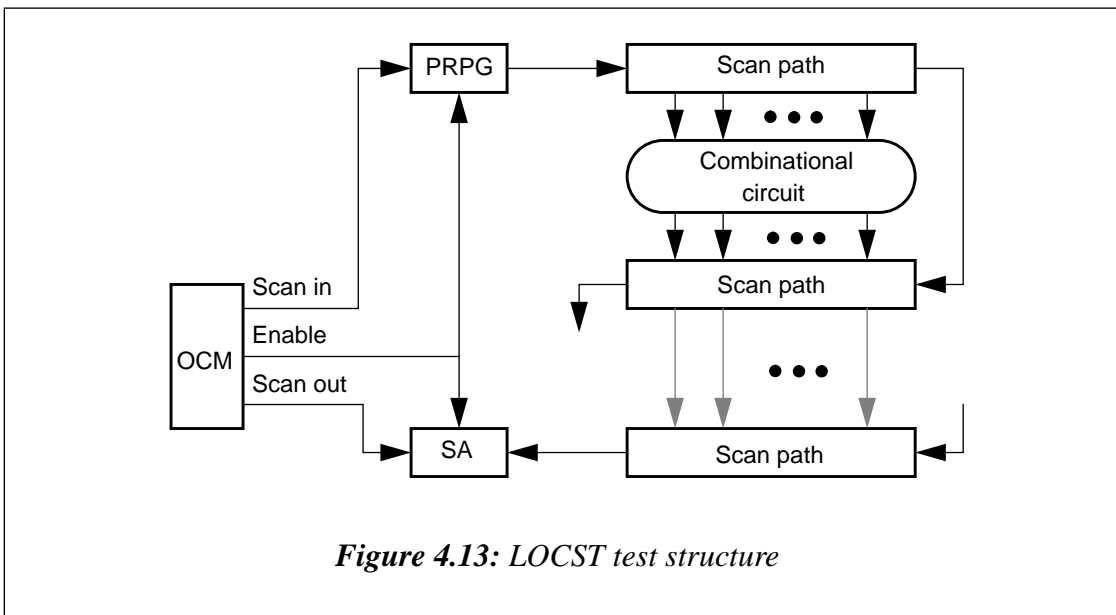

Figure 4.13: LOCST test structure

In self-test operation mode all the latches of the LOCST design are configured into a long scan register. The first twenty latches of the design are reconfigured into a PRPG with maximal length to generate pseudo-random patterns. The last sixteen latches of the scan path are modified into a signature analyser, SA, to collect test data received from the scan path register. The reconfigurations of the PRPG and SA are controlled by the OCM. During self-testing of the chip the pseudo-random sequence generated by the PRPG is scanned into the scan register. When the register is full the OCM produces a clock to store the response of the combinational logic into the same register. After that the content of the scan register is shifted out to the SA. This test cycle is repeated until the required number of pseudo-random patterns have been applied to the network. At the end of the test the signature collected into the SA is compared with the good signature. Clearly, the overall fault coverage of the LOCST technique depends on the extent of the logic whose inputs and outputs can be accessible by using the scan latches. The OCM and any embedded RAMs of the chip can not be tested by the LOCST technique.

The main disadvantage of this self-test method is that the test time proportionally depends on the length of the scan path. As a result, the LOCST technique cannot be used for any VLSI design with an arbitrary number of memory elements.

STUMPS approach

The major disadvantage of the LOCST self-test technique can be overcome if the PRPG is reconfigured to supply several scan path registers with pseudo-random patterns in parallel. The test data obtained from these registers are compressed using a parallel signature analyser. Such a self-test approach was named the STUMPS approach [37]. The general structure of the STUMPS approach is shown in Figure 4.14.

This technique drives the scan paths of LSSD chips. Once all the shift registers are loaded a system clock is activated so that the test results are stored in some of the SRLs on the chips. This data is then off-loaded into the parallel signature analyser. The time of testing such design depends on the length of the longest scan path.

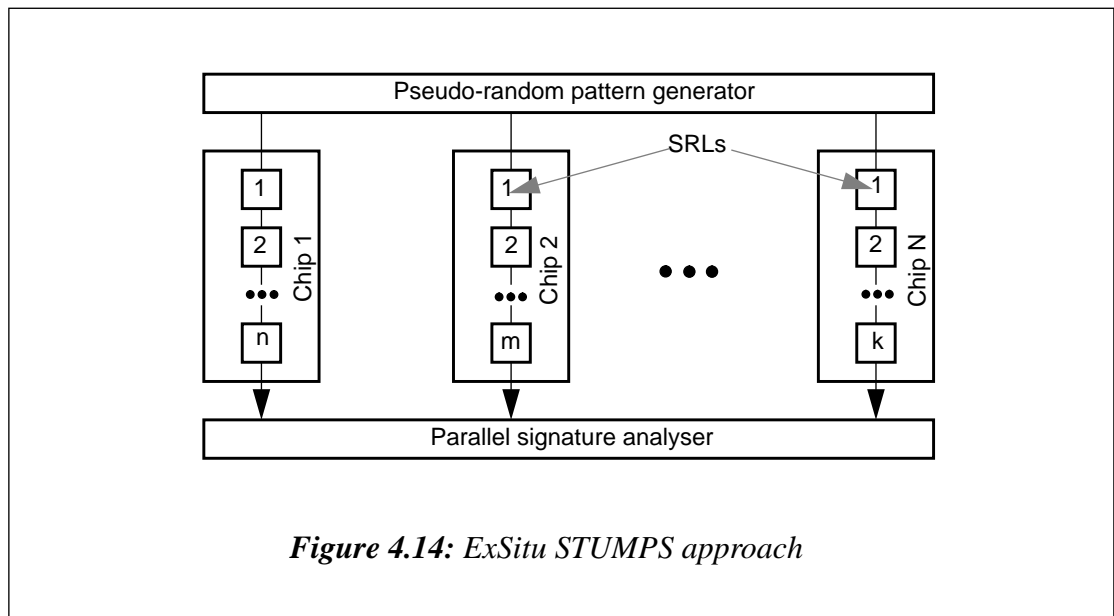

4.5 Summary

It is clear that one particular DFT method cannot solve all the problems concerned with testing VLSI circuits. Each DFT technique can solve only a subset of test problems with the help of increasing the degree of testability of the VLSI circuit to be tested. The most widely used DFT systems use a reconfigurable structure which permits the combinational logic and the memory elements to be separated for test purposes. The combinational circuit is tested in isolation. All the memory elements are formed into a long shift register or RAM to feed the inputs of the combinational network with tests and store the responses for inspection as in the case of scan path techniques. Self-test methods allow the generation and compression of test data inside a chip which alleviates the problem of operating with a large amount of test data.

The advantages of DFT methods for VLSI circuits are not achieved without a cost measured usually in terms of silicon overhead. Estimates vary typically from 4% to 20%. The true figure for the silicon overhead for a particular DFT approach is not easy to derive because it depends on many factors such as the structural characteristics of the VLSI circuit, the desired test time, test generation methods and so on. Performance degradation

and reduction in reliability due to extra components in the signal path are other serious penalties of using DFT methods. The justification for incurring these or other costs of DFT lies in the savings in test-related costs.

Chapter 5 : Testing asynchronous VLSI designs - related works

5.1 Problems with testing asynchronous VLSI circuits

Despite the essential advantages of using asynchronous designs the testing of asynchronous VLSI circuits remains a difficult problem due to the following reasons:

- asynchronous circuits often include races and are susceptible to incorrect operation due to hazards;
- to derive an iterative model for the circuit it is necessary to identify all feedback wires which requires an expensive analysis of the topology of the circuit;
- the correctness of the asynchronous circuit often depends on delays incorporated into the circuit, whereas the most test generation algorithms ignore delays;
- most asynchronous designs use a certain amount of hardware redundancy to avoid hazards, which compromises testability;
- the absence of a global clock makes the application of test techniques for combinational circuits hard to adapt to the testing of sequential circuits;
- asynchronous designs use a large number of storage elements (such as Muller-C elements, toggles etc.) which do not allow the use of DFT techniques due to the prohibitively large extent of the resulting hardware redundancy.

The publications devoted to the testing of asynchronous designs can be classified according to the objects under test. The first group deals with testing bounded-delay asynchronous circuits, the second one considers some possible solutions to the testing of

delay-insensitive circuits, and the third group of works is devoted to the problem of testing speed-independent asynchronous designs. This chapter is structured accordingly. Although micropipelines are inherently bounded-delay asynchronous circuits, the issues in the fault simulation and testing of micropipelines are discussed in the last section of the chapter since this is the main topic of this thesis.

5.2 Testing bounded-delay circuits

The most obvious model to use for asynchronous circuits is the Huffman model for digital networks which is widely used for designing synchronous circuits. To design an asynchronous circuit it is assumed that the delays of all the logic elements and wires are known in this model, or at least bounded. The same techniques of designing combinational circuits are used to build combinational networks in asynchronous VLSI systems. All static and dynamic hazards must be removed by adding extra logic elements [4]. Bounded-delay asynchronous circuits complicate the fault detection procedure. The adding of redundant terms to functions to eliminate hazards is in direct conflict with the fault testing technique which requires the avoidance of redundant terms to make faults visible [11]. The Huffman model for synchronous sequential circuits shown in Figure 4.3 can be used for designing bounded delay asynchronous circuits. Since we need to make sure that the combinational logic has settled in response to a new input before the present-state entries change, all the memory elements must be replaced by delay elements.

G. R. Putzolu and J. P. Roth have described an algorithm for generating tests to detect stuck-at faults in asynchronous sequential logic circuits [38]. This algorithm is based upon an extension of the D-algorithm. A general view of an asynchronous sequential circuit S was considered. It was assumed that a stuck-at fault F modifies only the logical function of S . The basic test strategy proposed consists of the following steps:

- 1) to transform the detection procedure of fault F in S into the detection of a corresponding set F' of faults in an iterative combinational logic circuit C' derived from S ;

2) to extend the D-algorithm to derive a test T for F^r in C^r ;

3) to simulate the test in S to verify whether or not T is a test for F .

An algorithm was described for selecting points in S at which to cut its feedback loops until S is transformed into an acyclic circuit C . After cutting feedback lines the original circuit S become acyclic as shown in Figure 5.1(a). Acyclic circuit C has primary inputs, PI , primary outputs, PO , and primary pseudo-inputs, SI , and pseudo-outputs, SO , which are introduced by the cutting points. If it is necessary to find a test for F in S of length r , that is a sequence of length r of primary input patterns which detects F , then F is modified into a sequence of r identical combinational networks C_i , $1 \leq i \leq r$, with primary inputs PI_i , pseudo-inputs SI_i , pseudo-outputs SO_i and outputs PO_i . The pseudo-inputs of C_i are identical to the pseudo-outputs of C_{i+1} (see Figure 5.1(b)).

The modified D-algorithm is used to find a test for fault F^r in C^r with the following conditions:

1) the derived test cannot be dependent upon any of the pseudo-inputs SI of C^r ;

2) an effect of fault F must be visible at one of the primary outputs PO .

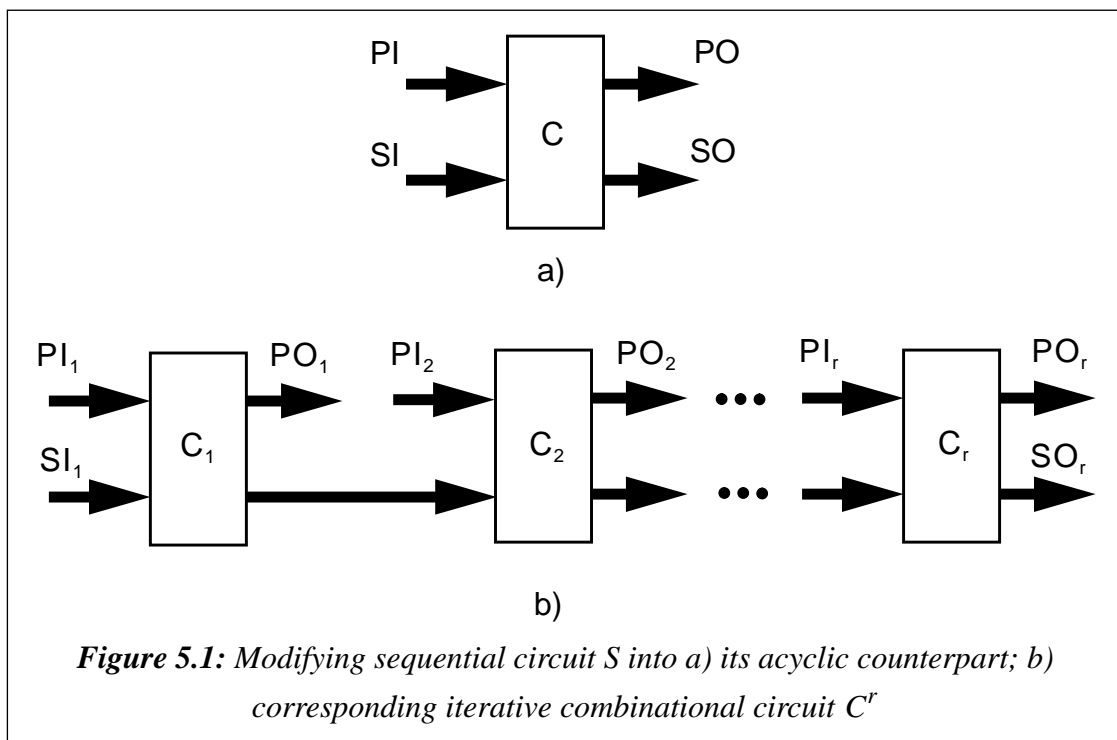

As a result, the test consists of an ordered set of r input patterns applied to the primary inputs PI of S . After that the behaviour of S is simulated while applying the derived set of patterns. If during the simulation no races or hazards are registered in S , then the test is accepted as a test for fault F in S .

The main drawbacks of this test generation algorithm are that:

- 1) it requires an extended analysis of the topology of the circuit to be tested;
- 2) it cannot guarantee the derivation of a race and hazard free test.

S. G. Chappell has proposed another approach to testing bounded-delay asynchronous circuits [39]. In this method Boolean equations are developed for the outputs of the circuit in terms of sequences of signals. The circuit model treats logic circuits as interconnections of unit- and zero-time-delay logic elements. The main features of this approach are:

- 1) all test sequences for detecting a specific fault can be derived;
- 2) some race conditions can be dealt with;
- 3) feedback lines need not be identified in the circuit.

The test generation algorithm is represented by the following steps:

1. Set the maximum sequence length $m=1$.
2. Generate equations for the circuit under test with sequence length m .
3. Obtain tests using maximum-cover strategy.
4. Simulate the derived tests. If the percentage of undetected faults is less than 10% then go to step 5. Otherwise, set $m=m+1$ and return to step 2.
5. Generate tests for remaining faults detectable with sequence length m .

6. If the percentage of undetected faults is less or equal to the desired fault coverage then stop. Otherwise, set $m=m+1$ and return to step 5.

The technique generates two equations denoted as $F^0(t)$ and $F^1(t)$ for each logic element in the circuit. These equations determine the input conditions required to set gate F to logical 0 and 1 respectively at time t . The technique starts from the circuit inputs and proceeds forward through the circuit. As a result, it is not necessary to identify feedback lines and combinational and sequential circuits can be treated by the same algorithm. The sequence length of the test indicates the number of input patterns required to detect a fault and propagate the fault effect to an output of the circuit. To generate all tests for a combinational circuit a sequence length of one is sufficient. Figure 5.2 shows an example of an R-S flip-flop which is realized using NAND gates. Let $a^0(i)$ and $a^1(i)$ denote logical 0 and 1 respectively on input line a during the i th vector of the sequence. The algorithm for deriving equations for an R-S flip-flop from an unknown state is shown in Table 5.1. It is assumed that in the initial state $F^0 = F^1 = G^0 = G^1 = 0$. The inputs are applied at time t . Only F^1 and G^1 changed values at time $t+1$. As a consequence, only G^0 and F^0 are calculated at time $t+2$. At time $t+3$, none of the output equations changed which means that the flip-flop has reached its stable state and computation stops. Similar computations can be carried out if the circuit is in a known initial state.

Equations for faulty circuits can be derived in the same way as for fault-free circuits. This approach allows the generation of tests for detecting stuck-at faults in asynchronous circuits. Faults in circuits are represented by fault variables x^0, i and x^1, i which

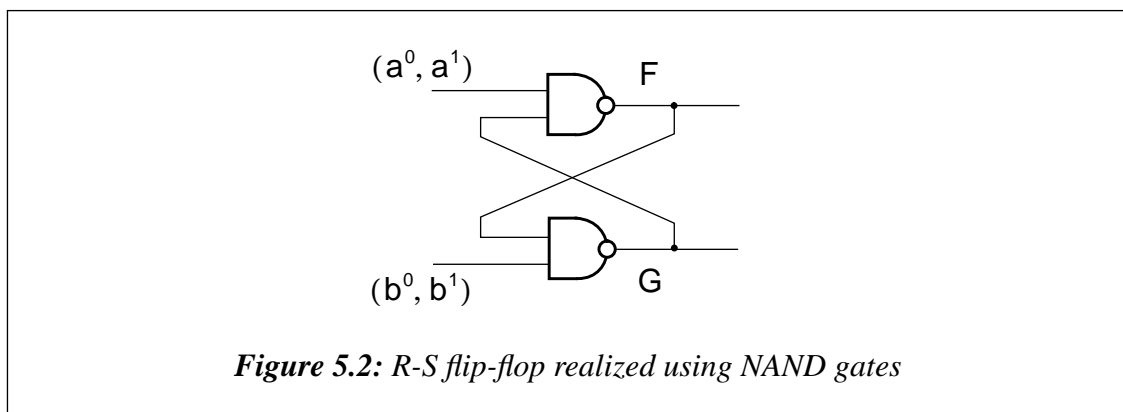

mean that the fault x, i is not present and is present in the circuit respectively. Parameter i is just a current number for the fault considered. These two states of a fault are used for making the comparison of the faulty and fault-free circuit to obtain a test detecting the fault. Figure 5.3 demonstrates equations for handling stuck-at faults in a NAND gate. The same analysis can be extended to asynchronous sequential circuits.

Table 5.1: Equations for an R-S flip-flop

time	F^1	F^0	G^1	G^0
t	0	0	0	0
$t+1$	a^0	0	b^0	0
$t+2$	a^0	$a^1 \cdot b^0$	b^0	$a^0 \cdot b^1$
$t+3$	$a^0 + a^0 \cdot b^1 = a^0$	$a^1 \cdot b^0$	$b^0 + a^1 \cdot b^0 = b^0$	$a^0 \cdot b^1$

The maximum-cover strategy is used to generate tests for stuck-at faults at each input of the circuit under test. This method allows the detection of around 90% of classical faults. The equations describing the circuit must be reasonably long which is specified *a priori*. Let output G of the circuit have the following equations represented in a general form:

$$G^0 = A + B \cdot x^1, i + C \cdot x^0, i;$$

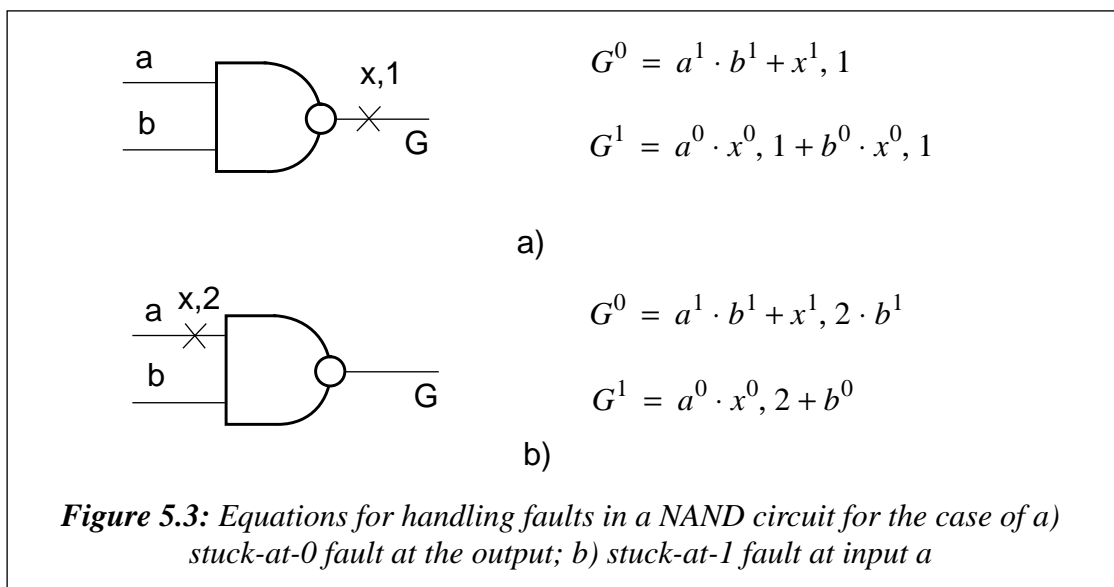

$$G^1 = D + E \cdot x^1, i + F \cdot x^0, i,$$

where A, \dots, F are also sum-of-products expressions. The tests to detect fault x, i at output G are defined by $B \cdot F + C \cdot E$. The basic idea of the maximum-cover strategy is that tests for all stuck-at faults on the primary input lines can also detect some other (internal) stuck-at faults of the circuit. For this purpose the output equations are factored as before, i.e.

$$F^0 = A + B \cdot a^1, j + C \cdot a^0, j;$$

$$F^1 = D + E \cdot a^1, j + F \cdot a^0, j.$$

Tests for fault j on input a are derived from the following expression:

$$(B \cdot F + C \cdot E) \cdot (a^1, j + a^0, j).$$

This expression, except for specifying the propagation conditions of the fault, determines the value to be assigned to input line a . The main drawback of the test generation technique described above is that it requires the detailed examination of the circuit to be tested. This leads to the computation time for the derivation of tests for VLSI designs increasing prohibitively.

A general description of asynchronous sequential circuits and their testability problems has been given by B. J. Heard [40]. A set of hardware modification techniques is described which allows asynchronous VLSI circuits to be tested by scan techniques. The use of special simulation techniques for flip-flops allows the generation of tests for asynchronous circuits on the basis of the D-algorithm. Two types of asynchronous designs were considered: circuits in which there is at least one flip-flop providing an asynchronous set/reset input to another flip-flop; circuits which contain at least one flip-flop providing the clock input to another flip-flop.

Figure 5.4a illustrates an example of an asynchronous reset network. This circuit cannot be tested by conventional scan techniques because:

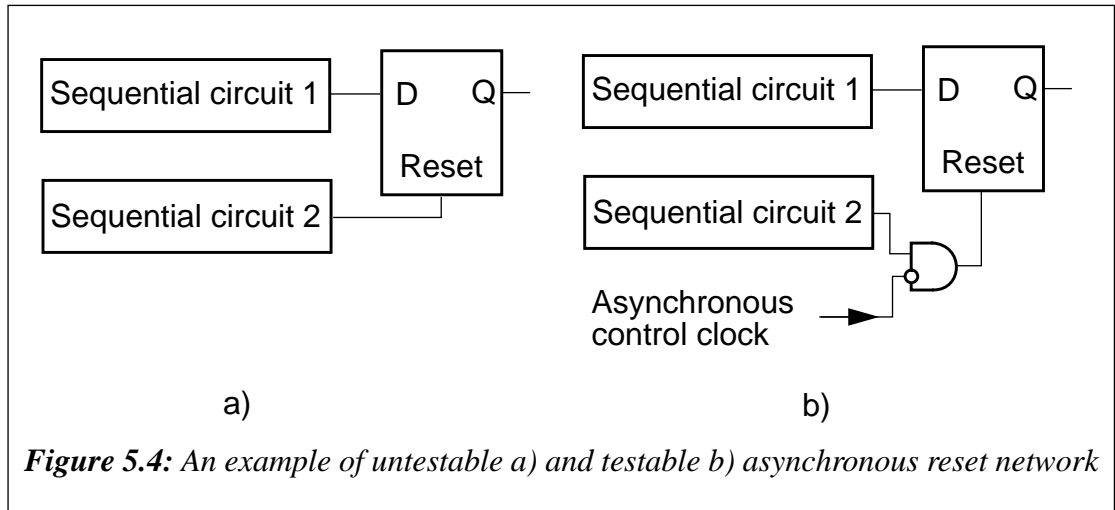

- 1) the asynchronous input can be activated while the test data are being loaded into the flip-flops of circuit 2 which can alter the data shifted into the D flip-flop;
- 2) the asynchronous input is sensitive to hazards which can take place on the output of circuit 2 during the test which, in turn, can change the response stored into the D flip-flop.

Figure 5.4b shows a solution which allows the asynchronous network to be made testable. The asynchronous control clock is controlled independently. When the asynchronous control clock is asserted to a logic one the synchronous logic (circuit 1) can be tested using scan methods. The asynchronous logic is tested when the system clock is held steady while the asynchronous control clock is pulsed. A set of software simulation

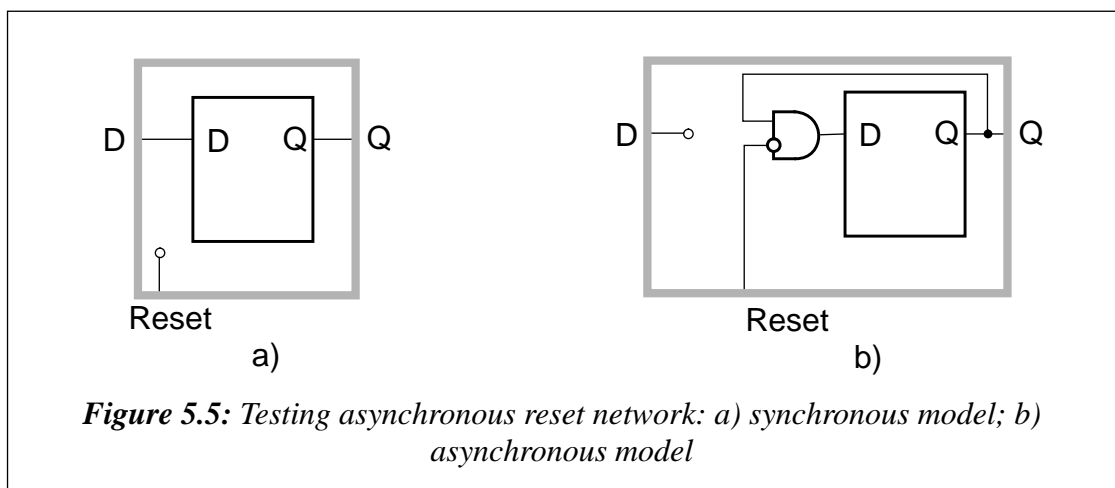

programs is proposed to generate tests for asynchronous set/reset circuits. The model shown in Figure 5.5a is used to simulate the synchronous test procedure. For simulating asynchronous testing, the model shown in Figure 5.5b is used.

This method for testing asynchronous circuits is oriented to the detection of only stuck-at faults and cannot solve the problem of identifying timing relationships between asynchronous signals inside asynchronous networks. The performance of such testable asynchronous circuits is affected by the extra delays of set/reset and clock lines. As a result, the designer must take into consideration the effects of these extra delays when calculating the timing characteristics of the circuit.

T. Fujieda and N. Zenke have described an original method for testing such asynchronous VLSI devices as Video RAMs, Dual Port RAMs and FIFOs [41]. The problem of testing these circuits is that they have two or more ports operating at different frequencies asynchronously and simultaneously. Conventional test methods are not able to check the asynchronous operation of multiple ports properly. The new method proposed allows the testing of two ports simultaneously and asynchronously by means of using the test system which includes two pattern generators and two timing generators.

An attempt to implement boundary-scan and pseudo-random BIST in an asynchronous transfer mode switch has been made [42]. The asynchronous transfer switch mode is capable of switching up to 16×1.244 Gbit/s. The switching function is essentially composed of a Double Access RAM which stores the incoming cells under supervision of a control circuit. Two types of faults in the Double Access RAM were considered implemented in CMOS technology:

- 1) stuck-open faults;
- 2) simultaneous reading and writing faults.

The proposed approach allows the detection of these faults during the test operation mode with fault coverage of 99.9%. During testing, all addresses and input stimuli are

produced by a PRPG and the responses are collected into a signature analyser. A special register was developed for testing the Double Access RAM.

C. Bellon and R. Velazco have proposed a behavioural test method for programmable circuits [43]. This method is based upon the notion of behavioural sequential machines and the identification principle. They described a system for automated generation of test programs for microprocessors. The system, besides generating tests, is capable of making a composition of timing diagrams of test signals. This simplifies testing such asynchronous functions of a microprocessor as interrupts caused by peripheral circuits.

The major disadvantage of the test approaches described above is that they were devised to test only special purpose asynchronous circuits and asynchronous functions inside synchronous designs. A set of formal methods was proposed to design testable asynchronous sequential circuits [44-46]. A. K. Susskind proposed to add one or at most two state variables, one extra input and to use one or more observable outputs in order to make the sequential circuit under test strongly connected and testable through scan-out features [44]. An asynchronous sequential network is strongly connected if any stable state can be reached from any other state. The scan-out technique is applied directly to the flow table describing the asynchronous sequential circuit to be tested. The test procedure proposed is based on verifying the flow table of the circuit under test. As a result, no fault models are used. The use of this approach is limited by the complexity of the circuit to be tested and becomes impractical for asynchronous VLSI circuits. The test technique does not guarantee both hazard-free operation and hazard-free robust path-delay-fault testability of asynchronous circuits. K. Keutzer, L. Lavagno and A. Sangiovanni-Vincentelli have described some heuristic techniques and procedures to design asynchronous circuits which are simultaneously hazard-free, robust path-delay-fault testable and hazard-free in operation [46]. The synthesis of asynchronous sequential circuits is performed using a high level specification, the signal transition graph. Using an appropriate delay model it is possible to design asynchronous circuits which are hazard-free. The test procedure uses scan techniques for applying each pair of test vectors to detect an appropriate path-delay-fault in a robust and hazard-free manner. In such asyn-

ynchronous circuits every latch can be scanned to increase controllability and observability of its inputs and outputs. It was shown that there is a negligible area or delay penalty required to achieve robust path-delay-fault testability. Nevertheless, the test approach imposes strict limitations on the speed at which the circuit can be tested.

5.3 Testing delay-insensitive circuits

P. Hazewindus made a successful proposal to adapt known test generation algorithms for testing delay-insensitive circuits using stuck-at fault model [47]. A technique to test delay-insensitive circuits was synthesized from a high-level specification. It used the high-level synthesis method for delay-insensitive circuits that was developed by A. J. Martin [6]. Two types of stuck-at faults in delay-insensitive circuits were considered: faults that cause the circuit to halt entirely, and faults which change the output of the circuit. The last kind of fault is either a stimulating or an inhibiting fault. The stuck-at fault is stimulating if this fault in a delay-insensitive circuit causes a production rule to fire when it should not. If a stuck-at fault in a delay-insensitive circuit may cause a production rule not to fire when it should then the fault is identified as inhibiting. It was assumed that the delay-insensitive circuits to be tested are non-redundant. In such a case for each inhibiting fault there is a state in the handshaking expansion where the fault causes a transition not to take place when it should; for each stimulating fault there is a state in the handshaking expansion where the fault causes a transition to occur when it should not. Thus, the testing algorithm is to force the faulty circuit to go in such a state (the state where the fault manifests itself) and to propagate the fault to an observable output of the circuit under test.

A combinational logic in a synchronous design is a feedback-free network of logic elements which calculates a function of the primary inputs. There are similar feedback-free delay-insensitive circuits which make their computations without buffering the result, although they contain state-holding elements. It was shown that any delay-insensitive circuit in which:

- 1) there are no feedback lines at the gate level;

2) each production rule for an up-transition (down-transition) has only positive (negative) literals in its guard;

can be reduced to a standard combinational logic circuit to ease the testing procedure. This combinational network is monotonic, and any test which detects all testable faults in this network will also detect all testable faults in the delay-insensitive circuit.

The standard D-algorithm can be extended to obtain a test pattern for a stuck-at fault in a delay-insensitive combinational circuit. Regular forward and backward propagation techniques can be used for such circuits. The major difference with combinational circuits is that there are some state-holding elements in delay-insensitive combinational circuits. It is necessary to take into consideration whether the circuit is in an up-going or a down-going phase for propagating a fault through a state-holding element.

Forward propagation. Let S be a state-holding element. Transform S into S_u by replacing the guard for the down-transition with the negation of the guard for the up-transition. Gate S_u is a combinational gate and is equivalent to S during the up-phase. Thus, the propagation of D and \bar{D} is the same for S as for S_u . For instance, if S is a C-element, then S_u is an AND gate. During a down-phase, S propagates a faulty signal if the output of the gate is 1 after the up-phase. Transform S into S_d by replacing the guard for the up-transition with the negation of the guard for the down-transition. Then S_d is a combinational gate which is equivalent to S during the down-phase, if the output of S is 1 after the up-phase. The propagation of D and \bar{D} is the same for S as for S_d . If S is a C-element then S_d is an OR gate.

Backward propagation. Transform S into S_u for the up-phase and S_d for the down-phase. The backward propagation for these combinational circuits is the same as it was described before. If S is a C-element with output D then all its inputs must be 1 for detection during an up-phase, and at least one input is 1 for detection during a down-phase. If the output is \bar{D} then during an up-phase at least one input is 0; during a down-phase all the inputs are 0.

Design for testability problems for delay-insensitive circuits were discussed. It was shown that each fault in a delay-insensitive circuit can be made testable by means of the addition of test points. These test points can be either control or observation points. If a premature firing is unstable then a control point is needed; if the premature firing is not propagated to a primary output then an observation point is needed. It was shown how to find a place where a test point must be inserted. For VLSI circuits which are pad-limited, it was proposed to merge the test points together into a queue. A fully testable design for such a test queue was derived.

The test approach for delay-insensitive circuits described above is efficient enough only for circuits of reasonable complexity, and becomes impractical for delay-insensitive VLSI circuits. Roncken and Saeijs have proposed a test strategy which can be integrated with the design of VLSI circuits through silicon compilation [48]. The strategy is based on a simple test procedure for which circuits are enhanced with a special mode of operation. As a result, the test generation time is linear in the size of the VLSI circuit.

5.4 Testing speed-independent networks

The problem of testing speed-independent circuits has already been addressed [49-50]. It was shown that live speed-independent circuits, which are strongly connected and composed of AND gates, OR gates and C-elements can be decomposed into a set of semi-modular networks. As a result, these circuits are self-checking with respect to certain classes of output stuck-at faults and input stuck-at faults. A live speed-independent circuit is a circuit whose signal graph is live, i.e. the signal graph is strongly connected and every transition of every signal is enabled in some valid state. A speed-independent circuit is semi-modular if its signal graph contains only transitions which do not disable other transitions.

The self-checking property of speed-independent circuits is due to the fact that a stuck-at fault can be considered as an infinite delay. Thus, a circuit whose operation depends on that delay will halt in the presence of that fault. Unfortunately, the class of faults for

which the self-checking property can be used for testing purposes is very limited and can hardly represent real faults in speed-independent circuits.

5.5 Testing micropipelines

One of the most detailed considerations of the problems of testing micropipelines has been made by Pagey, Sherlekar and Venkatesh [51]. It was noted that micropipelines have some advantages which make them easy to test. These are:

- the control circuits of the micropipeline are tested during normal operation mode;
- test generation for the data path of the micropipeline can be reduced to testing only combinational logic by means of minor changes in test operation mode;
- testing latches can be done by applying only two-pattern tests which can be generated using test generation techniques for combinational networks.

The single stuck-at fault model on all the lines (either logic or control lines) in the micropipeline was considered. Three classes of faults for the micropipeline were identified:

- faults in the control part of the micropipeline;
- faults in logic blocks;
- faults in the latches.

It was assumed that a stuck-at fault inside the latch can put a register bit of the latch in capture (stuck-at-capture fault) or pass (stuck-at-pass fault) mode permanently. The analysis of behaviour of the C-element was made in the presence of single stuck-at faults. If a stuck-at-1 or stuck-at-0 fault is present on the output of the Muller C-element then the Muller C-element remains in this state. If the Muller C-element was previously set to 1 (0) and there is stuck-at-0 (stuck-at-1) fault on one of its inputs then only one transition $1 \rightarrow 0$ ($0 \rightarrow 1$) can occur on the output of the Muller C-element.

Faults in the control part of the micropipeline

These are faults on the inputs and outputs of the Muller C-elements and the request and acknowledge lines of the micropipeline. Any stuck-at fault on a request or acknowledge line causes the micropipeline to halt since no events are produced in the control part of the micropipeline. As was shown above, any stuck-at fault on the inputs or the output of the Muller C-element allows at most one event to be generated on the output of the Muller C-element. As a result, in the presence of a stuck-at fault in the control part, the micropipeline advances through at most one step and then halts. Thus, stuck-at faults in the control part of the micropipeline manifest themselves by preventing activity in the micropipeline.

Faults in the logic blocks

If it is possible to set all the latches of the micropipeline in the pass mode then all logic elements can be treated as a single combinational logic block (see Figure 1.5). To detect any of the single stuck-at faults in such combinational logic test vectors can be obtained using any known test generation technique for combinational circuits. Therefore, the test procedure for the micropipeline contains two major steps:

- 1) the micropipeline is emptied, i.e. all the latches are set in the pass mode;
- 2) the test vectors are applied to the inputs of the micropipeline and the responses of the micropipeline are compared with good responses.

Faults in the latches

It is assumed that the combinational logic obtained after the latches have been set in the pass mode has no redundant faults. Figure 5.6 shows an example of an implementation of the event controlled latch. An event generated on the dotted line inside the latch causes a switch between two modes of the latch: pass and capture.

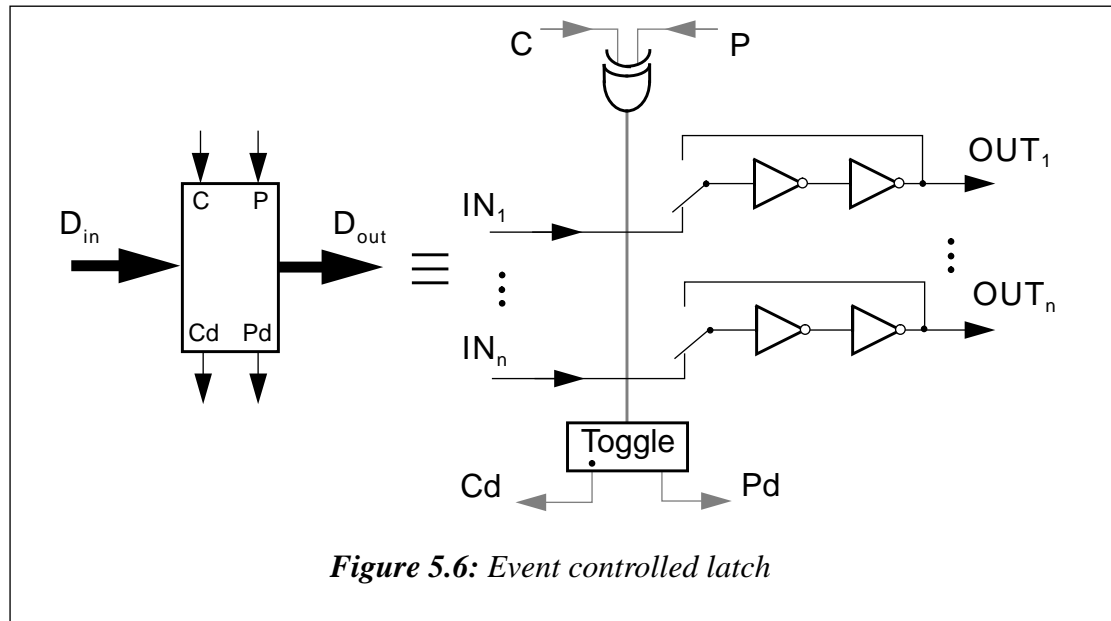

Single stuck-at faults. Any stuck-at fault on the inputs or outputs of the latch is equivalent to the appropriate fault in the combinational logic. A stuck-at fault on the control (dotted) lines of the latch (Figure 5.6) prevents the generation of any events in the latch. This causes the micropipeline to halt. The absence of activity in the micropipeline can easily be identified and, hence, there is no need for test generation for such faults.

Single stuck-at-capture faults. A single stuck-at-capture fault in a latch causes a register bit of the latch to remain permanently in capture position. As an effect of this fault, the faulty bit can be captured as a constant logic one or zero. When all the latches of the micropipeline are in the pass mode this fault is equivalent to an appropriate stuck-at fault on a line of the combinational logic. Thus, stuck-at-capture faults can be easily detected using standard tests for stuck-at faults in combinational networks.

Single stuck-at-pass faults. These faults make a register bit of a latch to be in the pass mode permanently. A two pattern test is required to detect this kind of faults. Consider a stuck-at-pass fault on a bit of the k th latch of the micropipeline. Let the faulty bit of the latch be connected to line l of the complete combinational network, CN, obtained by switching all the latches into the pass mode. The test for the faulty bit consists of two patterns, say P_1 and P_2 , which are applied one after another. Pattern P_1 is the test pattern for a stuck-at- z fault on line l of CN, where z is a logical value which is equal to 1 or

0. Pattern P_2 is the test vector which forces line l to be set to logical value z . These test patterns can be obtained easily by means of standard test generation methods for combinational circuits.

The test procedure for detecting a stuck-at-pass fault in the micropipeline is the following:

1. Apply pattern P_1 to the inputs of the micropipeline while all the latches are in the pass mode. Put the k th latch in the capture mode. As a result, line l has been set to logic \bar{z} . The response is observed at the outputs of the micropipeline.
2. Apply pattern P_2 to the inputs of the micropipeline. Thus, line l of CN has been driven to logic z since the faulty bit of the latch is connected to line l of CN; other lines of the latch are at their logical values corresponding to pattern P_1 . This causes at least one output of the micropipeline to be different from the fault-free response.

The result described above is the starting point in researching possible test approaches for micropipelines. The preliminary results show that tests for the single stuck-at type fault model can be generated using known test generation algorithms for combinational circuits. Problems which must be solved are

- designing appropriate methods for transferring the micropipeline from the normal operation mode to the test mode;
- testing delay faults either in CN or individual logic blocks;
- designing for testability.

Chapter 6 : Asynchronous random testing interface

Although DFT methods give test engineers a great opportunity to simplify the testing of either synchronous or asynchronous VLSI designs, test generation and fault simulation costs are still large and are rising with the increasing complexity of VLSI circuits. As a result, random testing becomes a viable alternative for testing asynchronous VLSI devices for at least two reasons:

- As shown in the previous chapters test generation methods for asynchronous VLSI circuits are more complicated than for synchronous ones, whereas the use of pseudo-random pattern generators (PRPG) for the random testing of VLSI circuits does not require any special properties from the CUT except that it does not have illegal input combinations.
- It is possible to use pseudo-random test patterns in asynchronous BIST VLSI structures.

Some asynchronous realizations of a PRPG and a signature analyser with the two-phase transition signalling communication protocol and a general description of software tools for simulating the behaviour of the universal PRPG are presented in this chapter.

6.1 Asynchronous implementations of PRPG and signature analyser

As asynchronous VLSI circuits perform their functions asynchronously the test procedure must be organized in the same (asynchronous) manner to correspond to the same asynchronous communication protocol between the CUT and test equipment. There are

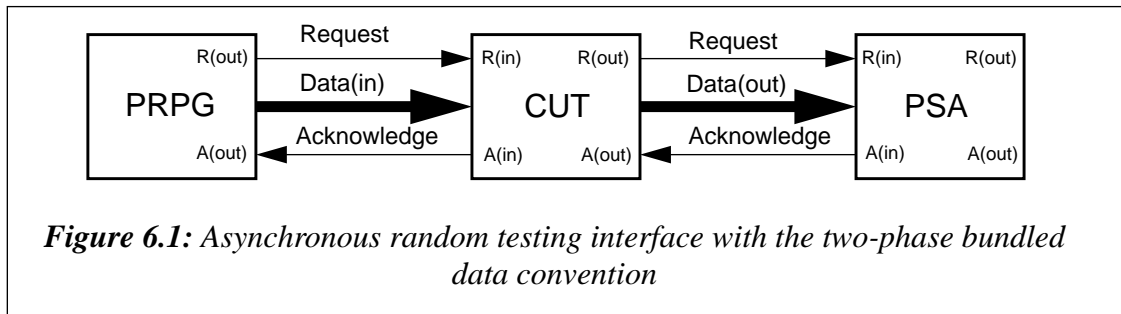

three major components in the random test procedure: PRPG, CUT and parallel signature analyser (see Figure 6.1). All the components of the structure operate using the two-phase bundled data convention mechanism. Test patterns are generated by the PRPG and the responses of the CUT are collected by the parallel signature analyser, PSA.

6.1.1 Asynchronous PRPG

The simplest way to realize an asynchronous version of the PRPG is the use of the synchronous PRPG which is clocked by the special asynchronous circuitry as illustrated in Figure 6.2. In the initial state the PRPG is set to the non-zero initial state and all the other lines of the asynchronous circuitry are set to logical zeros. As a result, the asynchronous PRPG produces a request signal on its output R(out). After receiving an acknowledge signal on its input A(out) the rising edge of the clock signal is generated

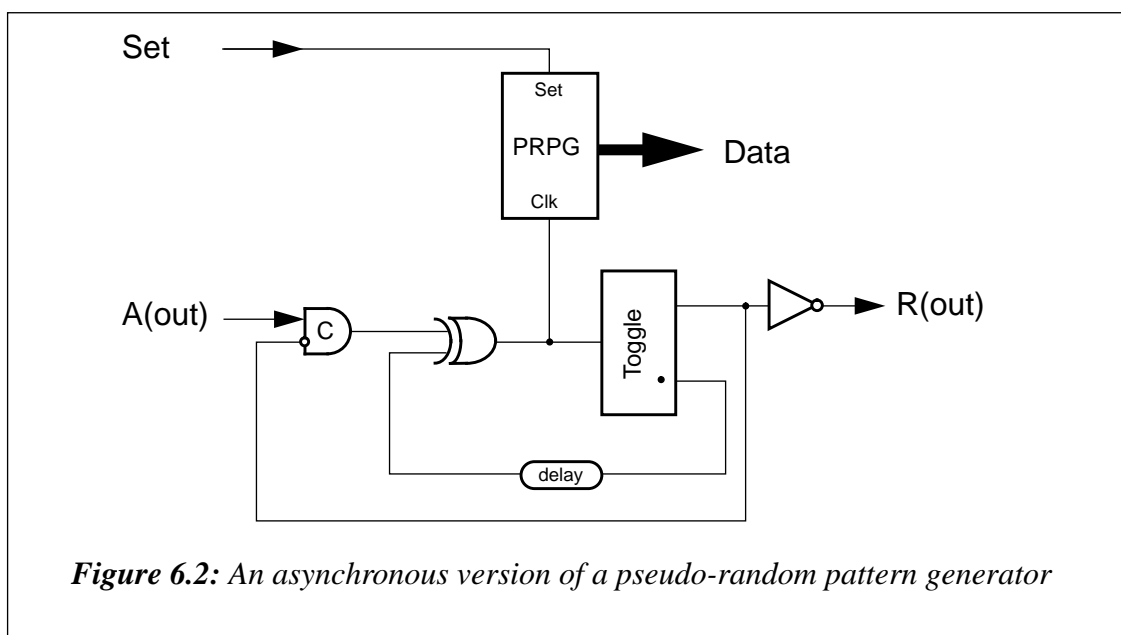

on the clock input of the synchronous PRPG. If the synchronous PRPG goes into a new state on a rising edge of the clock signal, then a new test pattern is generated on the outputs of the asynchronous PRPG. The Toggle element produces a rising signal transition on its output marked by the dot. This transition is delayed long enough for all the signal levels on the outputs of the PRPG to stabilize. After that a falling signal transition is produced on the clock input of the synchronous PRPG and the input of the Toggle element. The Toggle element generates a rising signal transition on its non-marked output. As a result, a new request event is produced in the form of a falling signal transition on output R(out). The procedure of generating a new clock signal for the synchronous PRPG is repeated after receiving a falling signal transition on the acknowledge input A(out) of the asynchronous PRPG. The structure and simulation results of the behaviour of the asynchronous 4-bit PRPG can be found in the appendix of the thesis. The simulation was done using the Powerview CAD tool (from Viewlogic Inc.).

The main advantage of this structure for the asynchronous PRPG is that it allows different types of synchronous PRPGs to be incorporated in it.

6.1.2 Asynchronous signature analyser

The basic idea of the asynchronous implementation of the signature analyser is the same as for the asynchronous PRPG, i.e. it involves a synchronous signature analyser with extra asynchronous logic which generates clock signals for the signature analyser and control signal transitions for the outside world. Figure 6.3 shows such an asynchronous parallel signature analyser. The main block of this structure is the synchronous parallel signature analyser, PSA. The synchronous parallel signature analyser is clocked by the asynchronous control logic which is an extended implementation of the same logic used in the asynchronous PRPG. The asynchronous control circuit produces the request and acknowledge events for the CUT, R(in) and A(in), and for a comparator, R(out) and A(out), which can be used for indicating a faulty behaviour of the CUT. Simulation results for the asynchronous 4-bit parallel signature analyser obtained by using the Powerview CAD tool are illustrated in the appendix of the thesis.

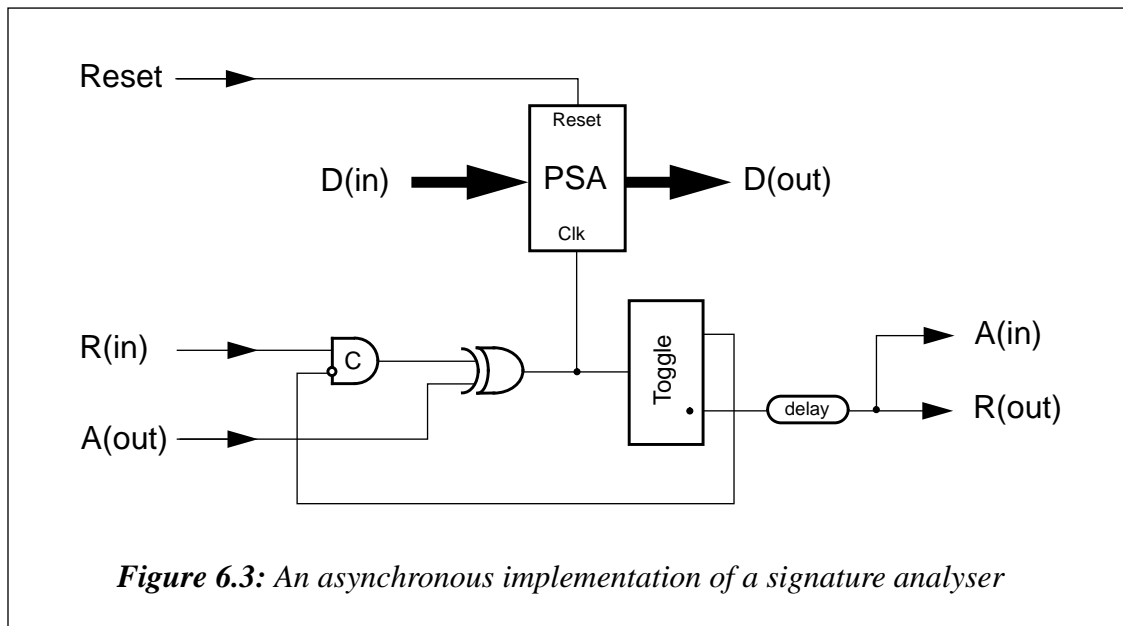

As in the previous case the structure of the asynchronous parallel signature analyser allows various types of synchronous signature analysers to be used to collect the responses from the CUT during its random testing.

6.2 Generating patterns for the random testing of asynchronous VLSI circuits

Some special structures of synchronous PRPGs which can be used effectively for the random testing of asynchronous VLSI circuits are discussed in this section.

6.2.1 Generating equiprobable test patterns

PRPGs based on LFSRs do not always produce pseudo-random test patterns which can be used effectively for the random testing of asynchronous circuits due to the presence of the shift operation used to generate each pattern.

Figure 6.4 shows the general structure of an asynchronous circuit which includes asynchronous logic, AL, and a latch for buffering the input data. In the initial state the outputs of the latch are set to the initial state and all the control lines are set to logical 0s. After receiving a request signal on input R(in) the asynchronous logic starts to operate

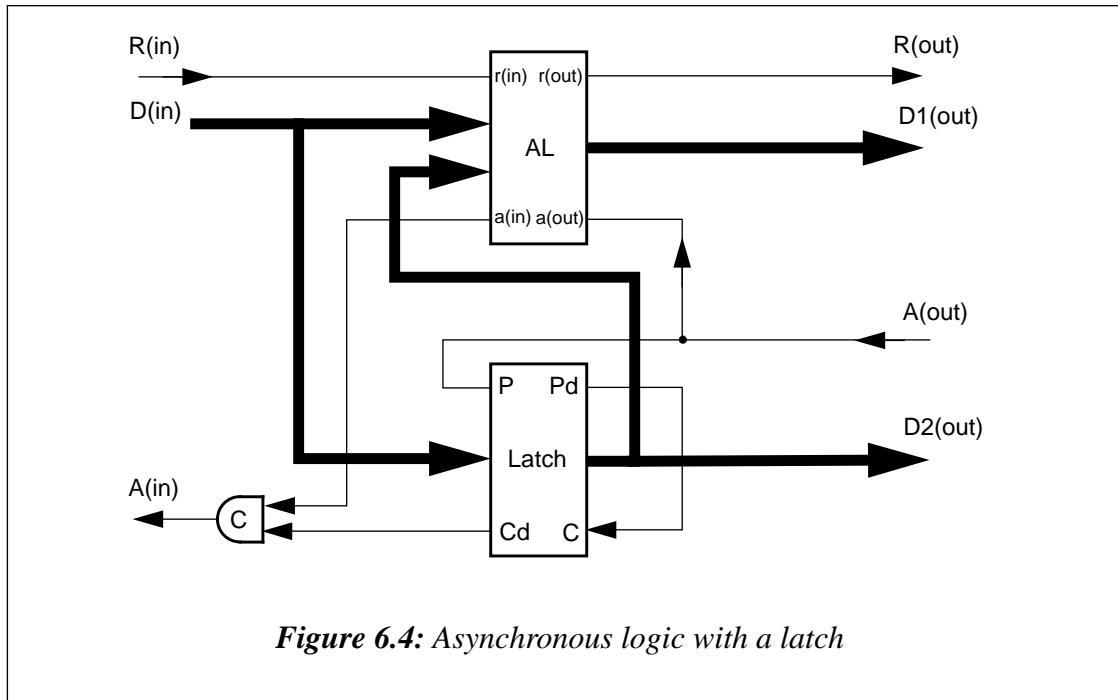

on the data from its inputs, $D(\text{in})$, and the outputs of the latch. When the operation is completed the asynchronous logic generates a request signal on its output $r(\text{out})$. As a result, a request event is produced on the output $R(\text{out})$ of the asynchronous circuit. After receiving the acknowledge event on the input $A(\text{out})$ the data from the input bus $D(\text{in})$ are stored in the latch and the circuit generates the acknowledge signal on its output $A(\text{in})$. If a new request signal appears on input $R(\text{in})$ the data operation procedure is reiterated.

An example of the asynchronous circuit described above with some faults is illustrated in Figure 6.5. The control lines are omitted to simplify the structure.

Let f_1 be a stuck-at-0 fault, f_2 be a stuck-at-1 or stuck-at-0 fault and f_3 be a bridging fault. These faults cannot be detected by random test patterns generated by LFSRs. Let the synchronous 4-bit LFSR (see Figure 3.3) incorporated into the structure of an asynchronous PRPG be a source of pseudo-random patterns. It is easy to check that in the pseudo-random test sequence (see Table 3.1) applied to the inputs of the circuit there is no test pattern which can force any of the faults to manifest itself. For instance, during the test 1) fault f_1 is untestable since only logical zeros are generated on the output of

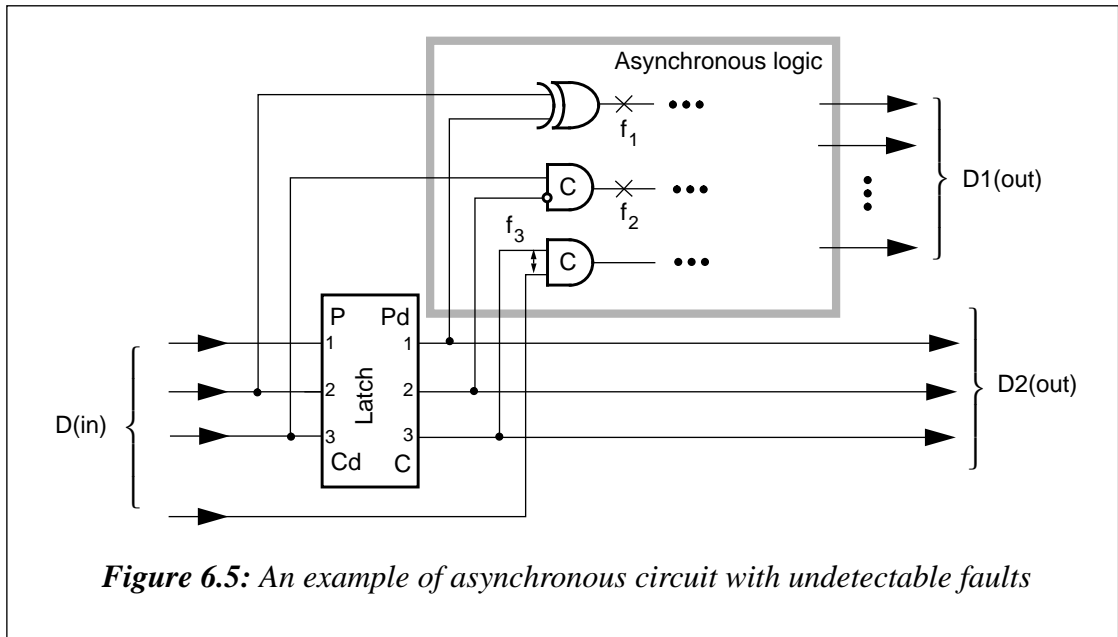

the XOR gate; 2) fault f_2 cannot be detected because the Muller-C element keeps its initial state unchanged (if the initial state of the Muller-C element is a logical 1(0), then stuck-at-1(0) fault f_2 is undetectable); 3) the bridging fault f_3 cannot be forced to manifest itself since only two input stimuli, 00 and 11, are generated on the inputs of the Muller-C element. The cause which makes these faults untestable lies in the nature of pseudo-random patterns generated by an LFSR which uses a shift register to produce the test patterns.

Let us build a PRPG which generates pseudo-random patterns on the basis of linear feedback but without the obvious shift operation. Table 6.1 shows the modification pro-

Table 6.1: State modifying table for the 4-bit LFSR

State	1	2	3	4
0	Q_1	Q_2	Q_3	Q_4
1	$Q_3 \oplus Q_4$	Q_1	Q_2	Q_3
2	$Q_2 \oplus Q_3$	$Q_3 \oplus Q_4$	Q_1	Q_2
3	$Q_1 \oplus Q_2$	$Q_2 \oplus Q_3$	$Q_3 \oplus Q_4$	Q_1
4	$Q_1 \oplus Q_3 \oplus Q_4$	$Q_1 \oplus Q_2$	$Q_2 \oplus Q_3$	$Q_3 \oplus Q_4$

cedure for the first four states of the 4-bit LFSR built using the derivation polynomial $\phi^r(X) = 1 + X^3 + X^4$. The pseudo-random sequence generated by this LFSR is the reverse sequence produced by the LFSR shown in Figure 3.3. It is possible to continue Table 6.1 to obtain expressions for all the states of the LFSR within the period. All these expressions (except the first one) determine the structures of PRPGs. For example, the fifth row (state number 4) defines the structure of PRPG which is equivalent to the structure shown in Figure 3.3 with the exception that all the flip-flops of the register are T flip-flops. Table 6.2 contains the state sequence for the PRPG built using T flip-flops and the derivation polynomial $\phi^r(X)$. As seen from the table the state sequence generated by the PRPG has the maximal period (15 clocks). There is no obvious shift operation in the generation of a new pattern. As a result, if these pseudo-random patterns are applied to the inputs of the asynchronous circuit shown in Figure 6.5, then all the faults, f_1 , f_2 and f_3 , can manifest themselves during pseudo-random testing.

Let us answer the following question: “Is it possible to use any of the rows in the state modifying table to obtain the PRPG of maximal length?” The answer to this question can be found after a detailed examination of the state sequence shown in Figure 6.2. Table 6.3 contains the results showing the equivalence between states of the three 4-bit PRPGs: the first column contains the state numbers of the PRPG built using T flip-flops,

Table 6.2: State sequence for the four-bit PRPG built using the state modification procedure

State	Q_1	Q_2	Q_3	Q_4	State	Q_1	Q_2	Q_3	Q_4
0	1	1	1	1	8	0	0	1	1
1	1	0	0	0	9	0	0	1	0
2	1	1	0	0	10	1	0	1	1
3	1	0	1	0	11	1	1	1	0
4	0	1	1	1	12	0	0	0	1
5	0	1	0	0	13	1	0	0	1
6	0	1	1	0	14	0	1	0	1
7	1	1	0	1	15	1	1	1	1

the second and third columns consist of the state numbers of the LFSR built using derivation polynomials $\varphi^r(X)$ and $\varphi(X)$ respectively. The final formula, which allows relationships to be established between the states of the generator built using the s_i th row from the state modifying table of the LFSR built using derivation polynomial $\varphi^r(X)$ (generator 1) and the LFSR of maximal length M built using derivation polynomial $\varphi(X)$ (generator 2), is the following one:

$$d = M - (s \cdot s_i) \pmod{M},$$

where d and s are state numbers of the generators 1 and 2 respectively.

Table 6.3: Table of equivalence between states of the three 4-bit PRPGs

State (s)	State in the reverse sequence (r) $s \times 4 \pmod{15}$	State in the original sequence (d) $(15-r)$	State (s)	State in the reverse sequence (r) $s \times 4 \pmod{15}$	State in the original sequence (d) $(15-r)$
0	0	15	8	2	13
1	4	11	9	6	9
2	8	7	10	10	5
3	12	3	11	14	1
4	1	14	12	3	12
5	5	10	13	7	8
6	9	6	14	11	4
7	13	2	15	0	15

For instance, in the case of the 4-bit PRPG, $s_i=4$ and $M=15$, the 5th state of the generator 1 is equal to the 10th state of the generator 2 ($10=15-(5 \cdot 4) \pmod{15}=15-5$).

The equation derived above allows us to find the condition when the generator 1 will be the PRPG of maximal length. This is the following condition: numbers s_i and M must have no common factors. Indeed, in the above example numbers 4 ($s_i=4$) and 15 ($M=15$) have no common factors and, therefore, the period of the 4-bit PRPG is 15 clocks.

Table 6.4: State modifying table for the 6-bit LFSR

State	1	2	3	4	5	6
0	Q_1	Q_2	Q_3	Q_4	Q_5	Q_6
1	$Q_5 \oplus Q_6$	Q_1	Q_2	Q_3	Q_4	Q_5
2	$Q_4 \oplus Q_5$	$Q_5 \oplus Q_6$	Q_1	Q_2	Q_3	Q_4
3	$Q_3 \oplus Q_4$	$Q_4 \oplus Q_5$	$Q_5 \oplus Q_6$	Q_1	Q_2	Q_3
4	$Q_2 \oplus Q_3$	$Q_3 \oplus Q_4$	$Q_4 \oplus Q_5$	$Q_5 \oplus Q_6$	Q_1	Q_2
5	$Q_1 \oplus Q_2$	$Q_2 \oplus Q_3$	$Q_3 \oplus Q_4$	$Q_4 \oplus Q_5$	$Q_5 \oplus Q_6$	Q_1
6	$Q_1 \oplus Q_5 \oplus Q_6$	$Q_1 \oplus Q_2$	$Q_2 \oplus Q_3$	$Q_3 \oplus Q_4$	$Q_4 \oplus Q_5$	$Q_5 \oplus Q_6$
7	$Q_4 \oplus Q_6$	$Q_1 \oplus Q_5 \oplus Q_6$	$Q_1 \oplus Q_2$	$Q_2 \oplus Q_3$	$Q_3 \oplus Q_4$	$Q_4 \oplus Q_5$
8	$Q_3 \oplus Q_5$	$Q_4 \oplus Q_6$	$Q_1 \oplus Q_5 \oplus Q_6$	$Q_1 \oplus Q_2$	$Q_2 \oplus Q_3$	$Q_3 \oplus Q_4$

Table 6.4 shows the state modification procedure for the first eight states of the 6-bit LFSR built using the derivation polynomial $\phi^r(X) = 1 + X^5 + X^6$. As the period of the 6-bit LFSR is 63 clocks, it is possible to use the 9th row of Table 6.4 ($s_i=8$) as a rule for modifying states of memory elements in order to obtain the 6-bit PRPG of maximal length (the numbers 8 and 63 have no common factors). Figure 6.6 shows the structure of this PRPG. The realization of such a 6-bit PRPG requires the use of more XOR gates than the equivalent LFSR and cannot allow the use of T flip-flops to obtain a simpler structure.

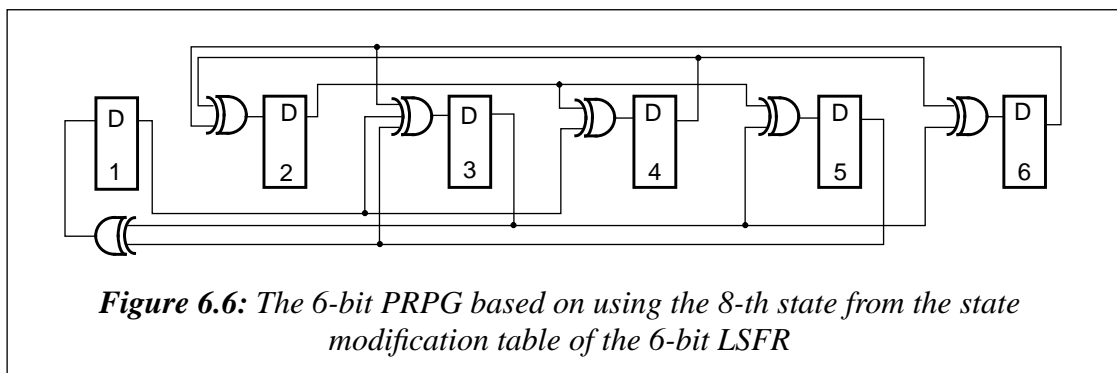

Thus, the implementation complexity of a PRPG to produce pseudo-random patterns without the obvious shift operation depends on:

- the number of outputs of the PRPG;
- the complexity of the derivation polynomial.

The technique for building PRPGs proposed in this section allows the creation of new structures for PRPGs which can be widely used for the pseudo-random (random) testing of various types of asynchronous VLSI circuits.

6.2.2 A PRPG for weighted test patterns

It was already noted that the derivation of tests from a source of equiprobable patterns to test data paths of digital circuits is not always an efficient procedure in terms of time and fault coverage [52-55]. The Monte Carlo method for logic testing of digital circuits has been proposed [53]. It was shown that in combinational logic the probability of detecting a stuck-at fault can be optimized by a proper selection of the probabilities of a zero and one on the outputs of the source of random test patterns. This fact was used for improving the efficiency of test generation over the commonly employed heuristics of equiprobable 0 and 1.

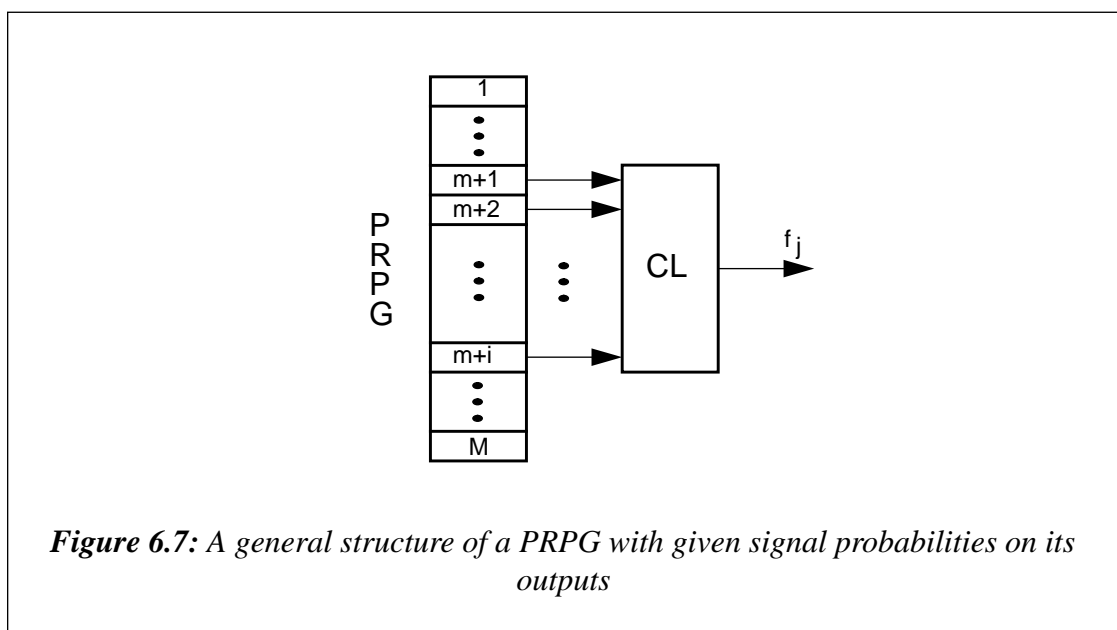

Figure 6.7 shows a general structure of a weighted pseudo-random pattern generator (WPRPG) which generates pseudo-random signals with a given probability of a one (zero) on its output f_j . In this structure the combinational logic, CL, is fed with a subset of the outputs of the PRPG which is the source of equiprobable patterns. The probability of a one and zero on the output of the combinational logic can be estimated as

$$p(f_j) = N_1 \cdot 2^{-i} \text{ and } q(f_j) = N_0 \cdot 2^{-i},$$

where N_1 (N_0) is the number of ones (zeros) in the truth table of Boolean function f_j .

Thus, the basic procedure for deriving the desired signal probability on the outputs of the WPRPG can be described by the following sequence of steps:

- put the desired number of ones (zeros) in the truth table of the Boolean function;
- make the minimal (in terms of logic elements) realization of the function.

The second step is important for obtaining a fast version of the WPRPG.

6.3 Program tools for the behavioural simulation of PRPGs

In order to have program tools for the simulation of the pseudo-random (random) testing of asynchronous VLSI circuits a behavioural model of the universal PRPG was designed. This simulation program for the universal PRPG is written in the C language. It includes three main programs (see Figure 6.8):

- *long_gps.c* which generates equiprobable pseudo-random patterns;
- *rom_prob.c* simulates the behaviour of the WPRPG based on using ROMs;
- *prpg_prob.c* which is a simulation program for the WPRPG based on using additional logic elements.

The key features of these programs are the following:

Long_gps.c generates:

- pseudo-random patterns by means of PRPGs designed using the technique described in subsection 6.2.1;
- pseudo-random n -bit test patterns, where n is a number from 2 to 127;
- pseudo-random patterns by means of using a composition of PRPGs which are started from different seeds.

Rom_prob.c produces:

- pseudo-random binary sequences of any desired period and with any desired probability of a one (zero).

Prpg_prob.c generates:

- pseudo-random signals with a probability of a one (zero) which is a fractional power of two.

Let us consider the structures of WPRPGs which are modelled by programs *rom_prob* and *prpg_prob*. Figure 6.9 shows a general structure of a WPRPG which generates weighted pseudo-random patterns using ROMs. In this structure, n ROMs are addressed by n different PRPGs. All the PRPG have different numbers of outputs. In the initializa-

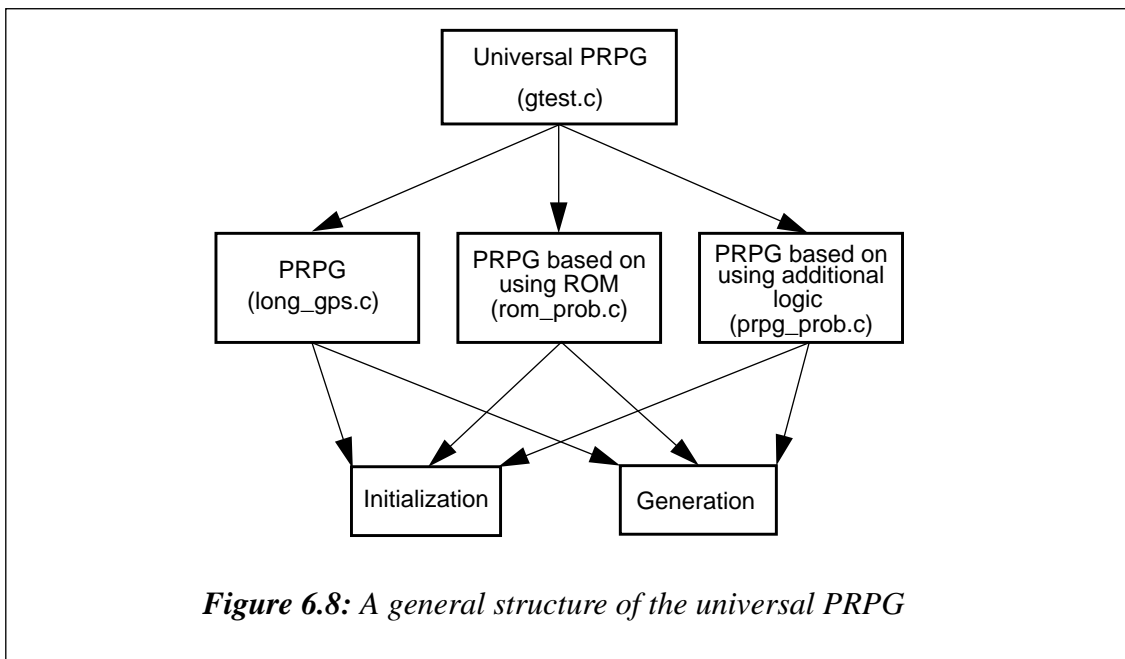

tion phase, the desired number of ones (zeros) are stored into the ROMs. Neither the relative placements of ones and zeros in the memory space of each ROM or the seeds of the PRPGs are significant. In the generation phase, the probability of a one (zero) on the i th output of the WPRPG can be calculated as follows:

$$p_i = N_{1i} \cdot 2^{-(N+i-1)} \quad (q_i = N_{0i} \cdot 2^{-(N+i-1)}),$$

where N_{1i} (N_{0i}) is the number of ones (zeros) in the i th ROM of the generator.

The period of the generator is equal to

$$T = (2^N - 1) \cdot (2^{N+1} - 1) \cdot \dots \cdot (2^{N+n-1} - 1).$$

The last formula can be approximated as follows

$$T = 2^{(0.5n(n-1) + Nn)},$$

where T is a number of clocks.

The structure of the generator illustrated in Figure 6.9 is flexible due to the possibility of generating pseudo-random sequences of any period (which depends on the number of

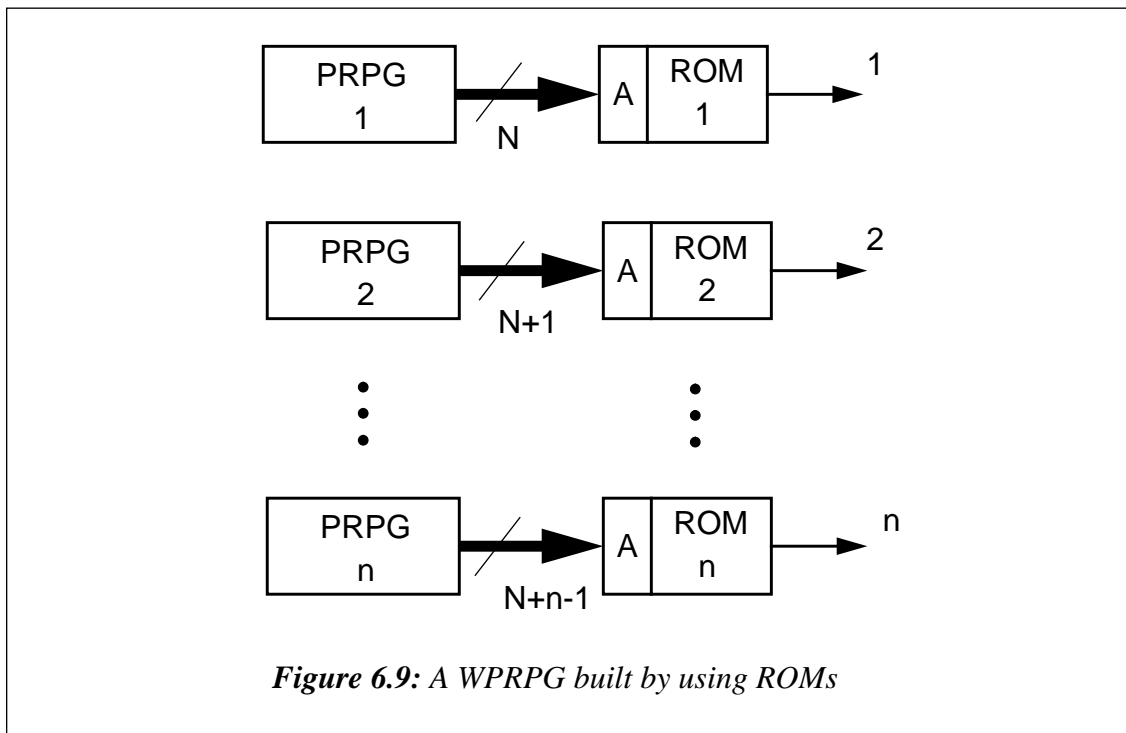

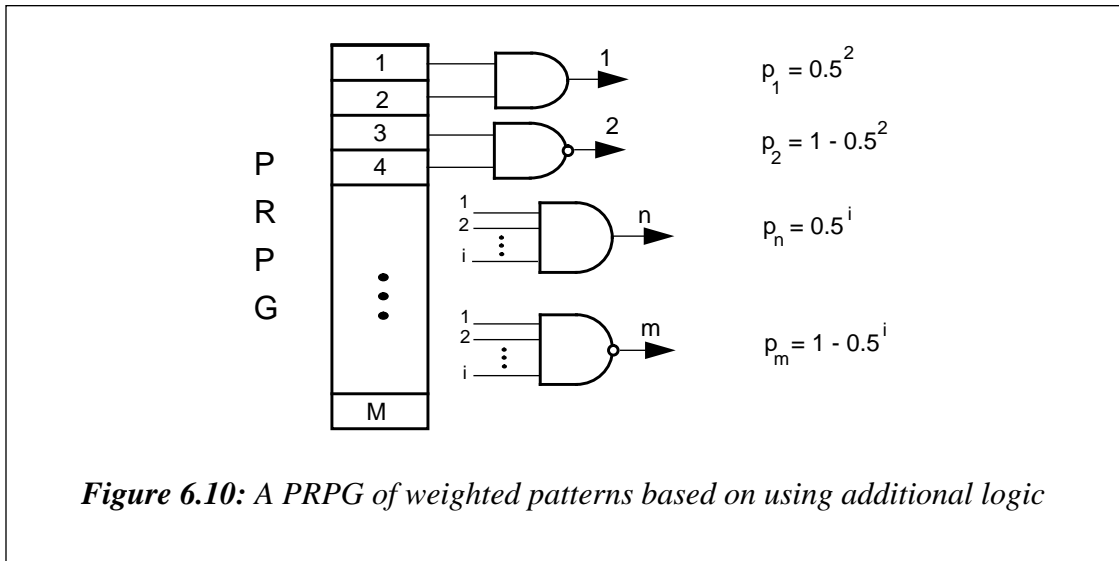

outputs of the PRPG) and with any desired probability of a one (zero) (which is determined by the number of ones (zeros) stored into the ROM).

The WPRPG illustrated in Figure 6.10 is simulated by program *prpg_prob*. This generator uses NAND and AND gates fed by the outputs of the PRPG. In the case of an AND (NAND) gate, the probability of a one is equal to

$$p_n = 2^{-i} \quad (p_m = 1 - 2^{-i}),$$

where i is a number of inputs of the gate.

The period of the generator is the same as that of the PRPG.

In conclusion it is necessary to note that:

- Although the WPRPG based on using ROMs can generate any desired signal probabilities on its outputs, the hardware redundancy of its realization is large. This kind of generator is principally for use in universal external testers for the random testing of either asynchronous or synchronous VLSI circuits.
- The WPRPG based on using additional logic elements is less complex and can be used as a source of pseudo-random test signals in either asynchronous or synchronous built-in self-test VLSI structures.

Chapter 7 : Test lengths for random testing of micropipelines

There are two important characteristics of random testing: the time taken to generate the desired set of test vectors, and the probability of detecting all possible faults from the predetermined class of the circuit's faults. The first parameter reflects the practical usability of the test set or simply the random pattern testability of the circuit under test. The second parameter is a characteristic of the quality of random testing.

Figure 7.1 shows a general structure for the random testing of a micropipeline all the latches of which are in the pass mode during the test. The primary inputs of the combinational logic, CL, are supplied with test patterns which are generated by the PRPG asynchronously. The responses from the primary outputs of the combinational logic are collected by the parallel signature analyser, PSA. The total test time of the micropipeline depends on the time for the random testing of the combinational logic, which basically consists of a number of subcircuits CL_i ($1 \leq i \leq w$). It is assumed that the number of outputs of the PRPG is larger than the number of inputs of the combinational circuit under test. This can be justified because usually random test equipment is universal and uses PRPGs which produce very long pseudo-random sequences. The question is, how is it possible to estimate the test length for the random testing of such a combinational network?

Past work has already addressed the question of determining the pseudo-random and random pattern test lengths [25, 56-58]. In some of these papers mathematical expressions are derived for the test length on the basis of the smallest detection probability of possible faults in the circuit [25, 56]. On the other hand, it was shown by J. Savir and P. H. Bardell [57] that the random pattern test length increases logarithmically with the number of faults which have a detection probability close to the minimum. The main

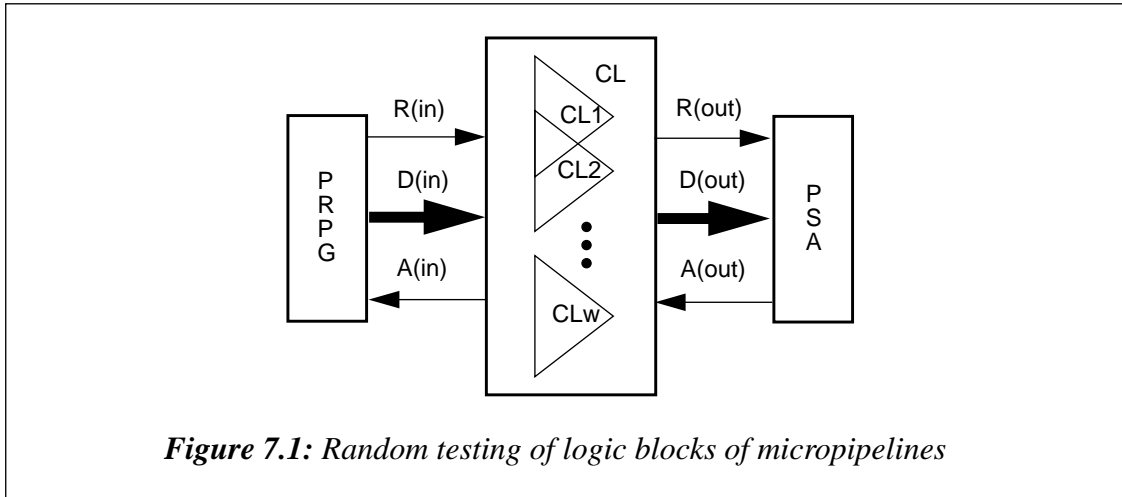

drawback of these results is that all of them assume that the detection probabilities of all hard-to-detect faults are known. This means that the internal structure of the circuit under test is known. But if the complexity of the circuit is high enough it is very difficult or even impossible to find all faults with small detection probabilities because of the huge number of faults. C. K. Chin and E. J. McCluskey proposed to evaluate the number of pseudo-random test patterns generated by a PRPG whose length is equal to the number of inputs of the combinational network to be tested [58]. Unfortunately, in practical random testing of VLSI circuits, this result can hardly be used for combinational circuits to be tested inside VLSI designs. All previous results were derived only for the case of equiprobable patterns applied to the inputs of the circuit.

In this chapter the test length for random pattern testing of logic blocks of micropipelines is estimated by applying equiprobable and weighted random test patterns to their inputs.

7.1 Test length for random pattern testing.

Suppose that to detect all faults from the predetermined class of the combinational network's faults it is necessary to generate on its n inputs the set, Q_m , of m ($m \leq 2^n$) test patterns. The test confidence probability threshold, p_t , is the probability that all necessary test patterns from Q_m will be applied to the inputs of the circuit under test, hence, the escape probability threshold of the test, $q_t = 1 - p_t$, is the probability that at least

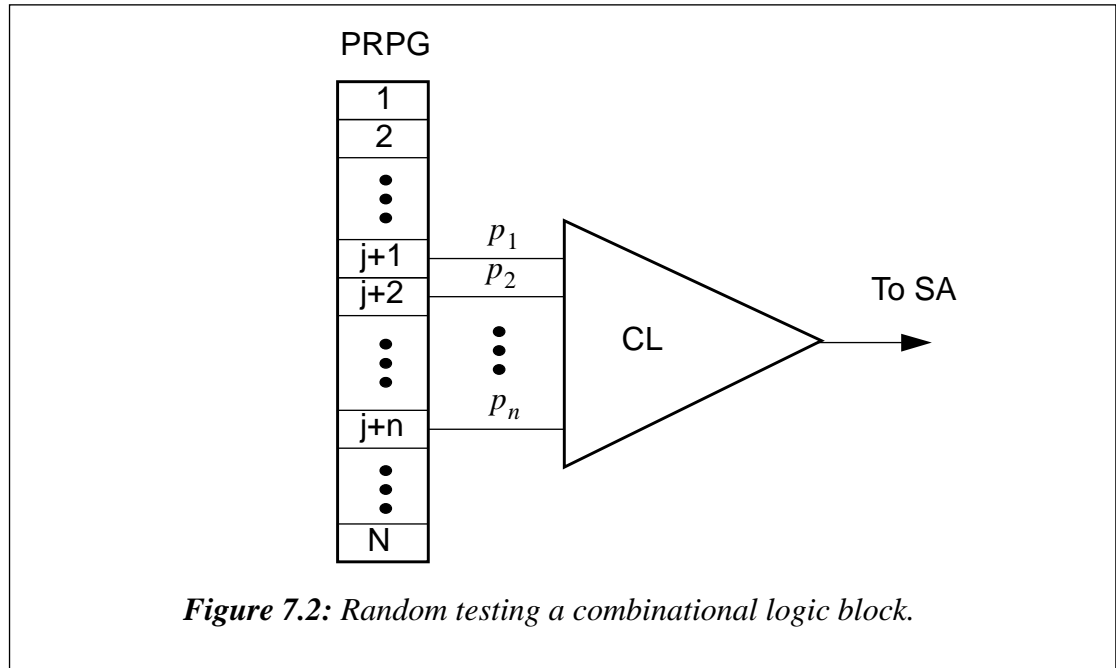

one pattern from the set Q_m will not be applied to the inputs of the combinational logic during the test. The test length, T_m , is the total number of test patterns applied to the inputs of the circuit.

Figure 7.2 shows the basic structure for pseudo-random testing an n -input combinational circuit. It assumes that the number of inputs to the combinational logic is fewer than the total number of storage elements of the PRPG. In this case it is possible to consider the pseudo-random test procedure as the random testing of the combinational logic by means of applying equiprobable test patterns to its inputs [58]. The probability that any one pattern will be generated on n outputs of the PRPG is $p = 2^{-n}$. During the random pattern testing of the combinational circuit the test results are observed in a compact form on the outputs of a signature analyser.

Let us estimate the random test length that is sufficient that m ($m \leq 2^n$) different n -bit test patterns to appear on the circuit's inputs. Consider the event \bar{E}_m when fewer than m of the required test vectors are generated on the inputs during the random test of length T_m . The event \bar{E}_m is the union of the m following events: the event \bar{A}_1 when pattern r_1 ($r_1 \in Q_m$) does not appear on the inputs; the event \bar{A}_2 when pattern r_2 ($r_2 \in Q_m$) does not appear, and so on up to event \bar{A}_m when pattern r_m ($r_m \in Q_m$) does not appear. The

events included in \bar{E}_m are not mutually exclusive, therefore the equation for the probability of \bar{E}_m , $p(\bar{E}_m)$, can be obtained with the help of a Venn Diagram [59]

$$p(\bar{E}_m) = \sum_{i=1}^m p(\bar{A}_i) - \sum_{\substack{i,j=1 \\ (i \neq j)}}^m p(\bar{A}_i) \cdot p(\bar{A}_j) + \dots + (-1)^{m+1} p(\bar{A}_1) p(\bar{A}_2) \dots p(\bar{A}_m) \quad (5)$$

As the probability $p(\bar{A}_i)$ is the escape probability of the test pattern r_i , taking into account the independent character of the test patterns which are used, the equation for the probability $p(\bar{A}_i)$ can be written as $p(\bar{A}_i) = (1-p)^{T_m}$, ($1 \leq i \leq m$).

Using the Venn Diagram it is possible to modify equation (5) into an inequality, i.e.

$$p(\bar{E}_m = \bar{A}_1 \cup \bar{A}_2 \cup \dots \cup \bar{A}_m) \leq \sum_{i=1}^m p(\bar{A}_i) = m \cdot (1-p)^{T_m}. \quad (6)$$

The probability $p(\bar{E}_m)$ should be no larger than the escape probability threshold, that is $p(\bar{E}_m) \leq q_t$. It follows from (6) that the inequality $m \cdot (1-p)^{T_m} \leq q_t$ suffices to ensure that all m test vectors will appear on the inputs with no less than the predetermined test confidence probability. Thus, the lower bound of the test length of the random test procedure, T_m , can be estimated as

$$T_m \geq \frac{\log(q_t/m)}{\log(1-p)}. \quad (7)$$

It is known [60] that if $p \rightarrow 0$ (i.e. the probability of generating one defined n-bit pattern is very close to zero) then $\log(1-p) \rightarrow -p$. Hence, if the number of inputs to the combinational network under test is large enough then inequality (7) will take the following form

$$T_m \geq 2^n \log(m/q_t). \quad (8)$$

Expression (8) can be derived from the Poisson theorem [60] because in the case when $p \rightarrow 0$ ($p = \text{const}$) and $T_m \rightarrow \infty$ the mathematical expectation of the number of appearances of one random pattern, a , during the test, is going to be a constant, i.e.

$a = T_m \cdot p \rightarrow const$. Therefore the probability, $P(a, k)$, that during the random test of length T_m the number of appearances of one pattern will be equal to k is the Poisson probability with parameters a and k :

$$P(a, k) \rightarrow e^{-a} a^k / k!, \text{ where } k = 0, 1, 2, \dots$$

The probability $p(\bar{A}_i)$ ($i = \overline{1, m}$) that only one pattern will not come out after the random test is the Poisson probability with $k = 0$:

$$p(\bar{A}_i) = P(a, 0) = e^{-T_m p}.$$

Taking into account that $p(\bar{E}_m) \leq q_t$ and (6) the expression (8) for the lower bound of the random pattern test length can be obtained.

To estimate the actual numerical values of the variable n which allows formula (8) to be used instead of (7) without losing significant accuracy it is reasonable to evaluate the relative error, ε , of the random pattern test lengths calculated by using formula (8):

$$(T_m'' - T_m) / T_m \leq \varepsilon, \quad (9)$$

where T_m and T_m'' are calculated from (7) and (8) respectively.

Substituting the corresponding expressions for T_m and T_m'' in inequality (9) the following inequality is obtained:

$$-\frac{\log(1-p)}{p} - 1 \leq \varepsilon.$$

As $p \rightarrow 0$ the inequality for ε can be rewritten using a limit, i.e.

$$-\lim_{p \rightarrow 0} \frac{\log(1-p)}{p} - 1 \leq \varepsilon.$$

It is known that $\lim_{p \rightarrow 0} \frac{\log(1-p)}{-p} = (1-p)^{-1}$. Therefore, the final inequality for the relative error ε can be written in the following form: $(1-p)^{-1} \leq \varepsilon$. From this formula it is possible to find the inequality for n taking into account that $p = 2^{-n}$, i.e.

$$n \geq \log_2 \frac{1 + \varepsilon}{\varepsilon}. \quad (10)$$

For instance, if $\varepsilon = 0.1\%$ then according to expression (10) inequality (8) can be used instead of (9) for calculating the lower bound of the random pattern test length whenever $n \geq 10$.

When using random pattern testing it is important to know the number of storage elements, N , of the PRPG (or simply the length of the PRPG) which is sufficient to justify the use of a random pattern test model for predicting the test length. It is known that during random test of length T_m the most probable number (the mathematical expectation) of appearances of any one pattern from the set of all possible 2^n combinations of n Boolean variables is equal to $T_m \cdot 2^{-n}$. On the other hand, after the period of the PRPG the number of appearances of any Boolean combination on the n outputs ($n < N$) of the PRPG is equal to $2^N \cdot 2^{-n}$. Thus, the pseudo-random test length which is calculated from inequality (7) or (8) can make sense only in the case when $T_m \cdot 2^{-n} \leq 2^N \cdot 2^{-n}$, that is, when $N \geq \log_2 T_m$.

Experimental results from estimating the test lengths for exhaustive random testing.

If the internal structure of the combinational logic under test is not known then all the possible 2^n binary patterns should be applied to the circuit's n inputs to test it. The main advantage of the exhaustive testing technique is that if there are no faults in the combinational network which change the network into a sequential one, then the test patterns will be good for any fault model. Experimental results for the test lengths required to obtain all 2^n patterns on n outputs of the PRPG were derived with the help of the simulation programs which were described in the previous chapter. The number of storage elements in the PRPG modelled was chosen as 73 because the period of such a PRPG is very large and structure is very simple. For every value of the variable n , $(K \cdot L)$ values for the random pattern test lengths were obtained. All the simulation results were put into a table with K columns and L rows where all the elements, t_{ij} , in each row were

sorted into increasing order, i.e. $t_{i1} \leq t_{i2} \leq \dots \leq t_{iK}$, $1 \leq i \leq L$. The final result was obtained in the form of vector with K elements where

$$t_j = \frac{1}{L} \sum_{i=1}^L t_{ij}, 1 \leq j \leq K.$$

Each element t_j of the vector is a value for the statistical random test length \bar{T}_{2^n} with test confidence probability $p_t = j/K$, where $1 \leq j \leq K - 1$. The last element of the vector ($j = K$) has no meaning because in practice it is impossible to achieve absolute confidence in a random testing. In the simulation experiments the number of columns and rows were equal to 100, i.e. $K = 100$ and $L = 100$. Apparently, the larger L is the more precisely the value of the random test lengths can be calculated, that is the statisti-

Table 7.1: Statistical and theoretical random lengths for the exhaustive testing of combinational networks

n	p_t	\bar{T}_{2^n}	T_{2^n}	
			(7)	(8)
2	0.9	13	13	14
	0.95	15	15	17
	0.99	20	21	23
4	0.9	78	79	81
	0.95	89	89	92
	0.99	109	114	118
8	0.9	1965	2005	2009
	0.95	2134	2182	2186
	0.99	2500	2593	2598
10	0.9	9336	9451	9455
	0.95	10012	10160	10165
	0.99	11279	11808	11813
12	0.9	42978	43485	43500
	0.95	45727	46323	46340
	0.99	51148	52913	52932

cal random pattern test length will be closer to the theoretical value. The values of K , L and n chosen in the simulation were restricted by the available simulation time on the computers used for the experiment.

Some of the practical and theoretical estimates of the random test length are shown in Table 7.1. The column headed T_{2^n} contains the values of the test lengths calculated by using formulas (7) and (8). Statistical test lengths are placed in the column headed \bar{T}_{2^n} . In order to restrict the table size the results are presented only for $p_t=0.9, 0.95, 0.99$, and $n=2, 4, 8, 10$ and 12 . It can be seen from Table 7.1 that the simulation results are no larger than the theoretically obtained ones. This confirms that expressions (7) and (8) may be used to calculate the lower bound of the random test length. Formula (8) is less complex than (7) and in fact it can be used instead of (7).

7.2 Test length for random testing using weighted patterns

Random testing using only equiprobable random test patterns is not always the optimal test procedure for obtaining the minimal (or close to minimal) random pattern test length for a certain subset of test patterns from the set of all possible binary combinations. To reduce the length of random pattern testing, methods were derived for achieving optimal output signal probabilities for generators of weighted pseudo-random patterns (WPRPG) [54-55]. The aim of this section is to present an approach for estimating the random pattern test length, T_m , which will guarantee the test confidence probability, p_t , of obtaining the desired number, m , of weighted test patterns from the set Q_m . In general the source of random test patterns can be a WPRPG with different signal probabilities on its outputs. Let us calculate the minimal probability, p_{min} , of a random pattern from the set Q_m ,

$$\text{i.e. } \forall \alpha_i \in \{0, 1\}, (1 \leq i \leq n), p_{min} = \text{MIN}(p_1^{\alpha_1} \cdot p_2^{\alpha_2} \dots p_n^{\alpha_n}),$$

$$\text{where } (\alpha_1 \alpha_2 \dots \alpha_n) \in Q_m, p_i^{\alpha_i} = \begin{cases} p_i, & \text{if } \alpha_i = 1, \\ 1 - p_i, & \text{if } \alpha_i = 0. \end{cases}$$

Suppose that all m test patterns from the set Q_m have the same probability of appearance which is equal to p_{min} . Thus, the weighted random testing of a combinational logic cir-

cuit can be substituted on the random pattern testing by means of equiprobable test vectors. In this case for estimating the random pattern test length it is possible to use expression (8) where $p = p_{min}$, i.e.

$$T_m^U \geq p_{min}^{-1} \log (m/q_t) . \quad (11)$$

Obviously inequality (11) evaluates the redundant lower bound for the test length for the random testing with the help of the WPRPG.

Consider the case when the set Q_m contains only two test patterns with probabilities of appearance v_1 and v_2 respectively. The model of the generation of all these patterns during random testing can be represented by the Markov chain (Figure 7.3) with four states: S_0 and S_{12} are the states which correspond to the appearance of neither and both test patterns respectively; states S_1 and S_2 correspond to the appearance of the first and the second test pattern respectively. The transition probabilities between the states are marked on the transition arcs of the Markov chain. The initial state probabilities of the Markov chain are $P_0(S_0) = 1, P_0(S_1) = P_0(S_2) = P_0(S_{12}) = 0$.

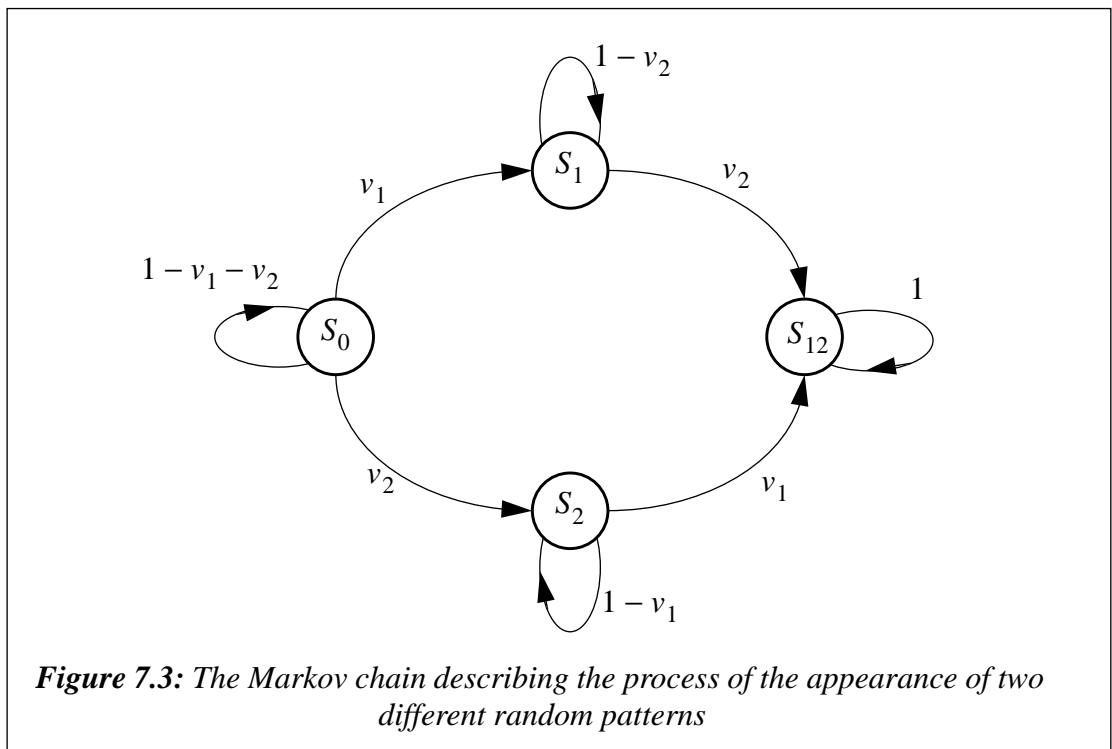

Let us estimate the probability $P_k(S_{12})$ that during the generation of k test patterns by the WPRPG the patterns from set Q_2 will appear. For this purpose the system of difference equations which describes the behaviour of the Markov chain (Figure 7.3) can be composed as:

$$P_k(S_0) = (1 - v_1 - v_2) \cdot P_{k-1}(S_0),$$

$$P_k(S_1) = (1 - v_2) \cdot P_{k-1}(S_1) + v_1 \cdot P_{k-1}(S_0),$$

$$P_k(S_2) = (1 - v_1) \cdot P_{k-1}(S_2) + v_2 \cdot P_{k-1}(S_0),$$

$$P_k(S_{12}) = v_2 \cdot P_{k-1}(S_1) + v_1 \cdot P_{k-1}(S_2) + P_{k-1}(S_{12}).$$

The solution of this system of difference equations subject to the initial conditions is given by

$$P_k(S_0) = (1 - (v_1 + v_2))^k; \quad P_k(S_1) = (1 - v_2)^k - (1 - (v_1 + v_2))^k;$$

$$P_k(S_2) = (1 - v_1)^k - (1 - (v_1 + v_2))^k;$$

$$P_k(S_{12}) = 1 - (1 - v_1)^k - (1 - v_2)^k + (1 - (v_1 + v_2))^k.$$

According to the condition of random pattern testing the probability $P_k(S_{12})$ should be no less than the test confidence probability p_t , hence,

$$1 - (1 - v_1)^k - (1 - v_2)^k + (1 - (v_1 + v_2))^k \geq p_t. \quad (12)$$

Inequality (12) can be simplified taking into account that $(1 - (v_1 + v_2))^k$ is a positive value which is less than either $(1 - v_1)^k$ or $(1 - v_2)^k$, i.e.

$$(1 - v_1)^k + (1 - v_2)^k \leq q_t. \quad (13)$$

Suppose that $v_2 = cv_1$, where $c = const$, $c \geq 1$. It follows from expression (13) that the larger parameter c is, the less effect probability v_2 has on the random pattern test length. In practice the random testing of n -input digital circuits presumes that the prob-

abilities of appearance of rare test patterns are very small (especially if n is large enough) and $k \rightarrow \infty$. Therefore, expression (13) can be approximated as

$$e^{-v_1 k} + e^{-c v_1 k} \leq q_t. \quad (14)$$

Let us estimate the value of parameter c that will change the test length, k , calculated from formula (14) by no more than the predetermined value of a relative error, ε . In other words, it is required to find c from the following inequality:

$$\left| \frac{k_1 - k_c}{k_1} \right| \leq \varepsilon, \quad (15)$$

where k_1 is the test length calculated from (10) when $c = 1$.

Let $x = e^{-v_1 k}$, hence, inequality (14) can be rewritten as

$$x^c + x - q_t \leq 0. \quad (16)$$

If $c = 1$ then the solution of inequality (16) is obvious: $x \leq q_t/2$, that is, $k_1 \geq v_1^{-1} \log(2/q_t)$. When $c = 2$ the solution of quadratic inequality (16) is the following: $x \leq (\sqrt{1 + 4q_t} - 1)/2$ (the second root of quadratic equation (16) is negative whereas $x \geq 0$), therefore, $k_2 \geq v_1^{-1} \log(2/(\sqrt{1 + 4q_t} - 1))$. Substituting k_1 and k_2 in (15) the following inequality is derived:

$$\frac{\log((\sqrt{1 + 4q_t} - 1)/q_t)}{\log(2/q_t)} \leq \varepsilon. \quad (17)$$

When $c = 3$ it is necessary to solve the cubic inequality (16). Cubic equation (16) has three roots: one is real; the other two are complex conjugate roots [60]. As x should be a positive real value then the solution of cubic inequality (16) can be found as $x \leq \sqrt[3]{\sqrt{D} + q_t/2} - \sqrt[3]{\sqrt{D} - q_t/2}$, where $D = 1/27 + q_t^2/4$, therefore,

$k_3 \geq v_1^{-1} \log \left[\sqrt[3]{\sqrt{D} + q_t/2} - \sqrt[3]{\sqrt{D} - q_t/2} \right]^{-1}$. Substituting the expression for k_3 in (15) the following inequality is obtained:

$$\frac{\log \left[\left(\sqrt[3]{\sqrt{D} + q_t/2} - \sqrt[3]{\sqrt{D} - q_t/2} \right) \left(\frac{2}{q_t} \right) \right]}{\log (2/q_t)} \leq \varepsilon. \quad (18)$$

Table 7.2 shows the results of numerical solutions of equation (15), i.e. $\varepsilon = \varepsilon(c, q_t)$, for $c = 2, 3$ and different values of variable q_t . The columns marked as $\varepsilon(2, q_t)$ and $\varepsilon(3, q_t)$ represent the solutions of equations (17) and (18) respectively.

Table 7.2: Numerical solutions of inequalities (17) and (18)

q_t	$\varepsilon(2, q_t)$	$\varepsilon(3, q_t)$
0.001	9.1%	9.1%
0.01	12.9%	13.1%
0.05	17.5%	18.7%
0.1	20.2%	22.8%
0.2	23.3%	28.5%
0.3	25.1%	32.6%
0.5	27.5%	38.1%

Figure 7.4 shows a graph of the dependence of the relative error ε on the escape probability q_t for $c = 2, 3$. It can be seen that the solutions of inequalities (17) and (18) lie beneath the appropriate curves and $\varepsilon(2, q_t) \leq \varepsilon(3, q_t) \leq \varepsilon(4, q_t) \leq \dots$. From Table 7.2 and Figure 7.4 it can be seen that values $\varepsilon(2, q_t)$ and $\varepsilon(3, q_t)$ are very close together for high confidence random pattern testing. Thus, choosing a value of variable c which is more than 2 does not significantly affect the random test length with the high test confidence probability. In other words, if the probability of one test pattern is more than twice the minimal probability of a test pattern from set Q_m then to estimate the lower bound for the random pattern test length it is sufficient to take into account the probabilities of test patterns which belong to the range $[p_{min}, 2p_{min}]$. Therefore, the final algorithm for calculating the lower bound for the test length for random testing by means of applying weighted test patterns can be described as the following sequence of steps:

- i) compute the minimal probability of a test pattern from set Q_m, p_{min} ;
- ii) calculate how many test patterns, g , have a probability of appearance no larger than twice the minimal probability p_{min} ;
- iii) estimate the random pattern test length as

$$T_m \geq p_{min}^{-1} \log (g/q_t) . \tag{19}$$

Example. Let us calculate the test length for the optimal random pattern testing of a 10-input AND gate ($n = 10$) where $q_t = 0.01$. For optimal random testing of AND gates the signal probability of each output of the WPRPG should be $p_o = (n - 1) / n$ [55]. It is known that the test set for the testing of all stuck-at faults of an n -input AND gate consists of $(n + 1)$ test vectors, i.e. for the case of 10-input AND gate the test set contains ten 10-bit “running zero” test patterns and one pattern which includes all ones. The minimal probability of appearance is for the “running zero” test pattern: $p_{min} = p_o^{n-1} (1 - p_o)$ or for the case of 10-input AND gate $p_{min} = 0.038$. The proba-

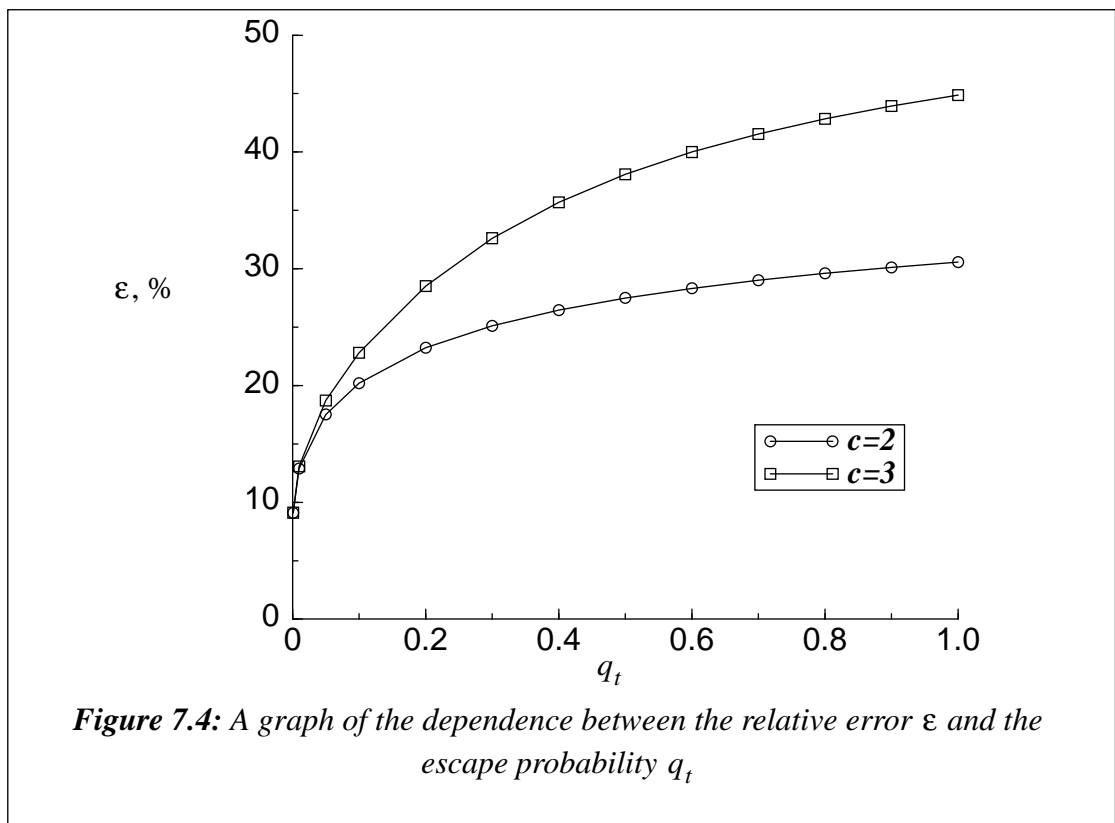

bility, p_{t1} , that “all ones” test vector will appear is p_o^n . As $n = 10$, $p_{t1} = 0.348$. The probability p_{t1} is much more than two times larger probability p_{min} , therefore, $g = 10$. To calculate the test length for the optimal random pattern testing of a 10-input AND gate expression (19) is used, i.e. $T_{11} \geq 178$. In comparison with random testing using equiprobable random test patterns ($T_{11} \geq 7171$) the random pattern test length is reduced by a factor greater than 40.

Table 7.3 contains some experimental and theoretical results for evaluating test lengths for the exhaustive random testing of a 3-input combinational circuit. The test lengths calculated from expression (19) are shown in the column headed T_{2^n} . The simulation results are in the column \bar{T}_{2^n} . Table 7.3 confirms that formula (19) can be used in practice for predicting the number of weighted random test patterns needed for the testing of a combinational circuit.

Table 7.3: Theoretical and experimental results for estimating the test lengths for random pattern testing of a 3-input combinational circuit

p_1	p_2	p_3	p_{min}	g	p_t	T_{2^n}	\bar{T}_{2^n}
0.125	0.25	0.5	0.016	2	0.9	192	183
					0.99	339	310
0.1	0.25	0.5	0.013	2	0.9	240	231
					0.99	424	396
0.125	0.125	0.25	0.003	1	0.9	590	588
					0.99	1179	1083
0.25	0.333	0.5	0.042	2	0.9	72	70
					0.99	128	115
0.033	0.1	0.5	0.002	2	0.9	1816	1755
					0.99	3212	2954

7.3 Summary

In this chapter mathematical expressions were derived for predicting the test length for random pattern testing of micropipelines by means of applying to their inputs equiprobable and weighted patterns. It was shown that to estimate the lower bound for the test length using equiprobable random test patterns it is possible:

- i) to use the assumption that appearances of all test patterns are mutually exclusive events;
- ii) to exploit the Poisson approximation for calculating the probabilities of these events.

It was proved that to evaluate more exactly the lower bound for the test length for random testing a combinational network by means of weighted test patterns it is sufficient to take into account the probability of the rarest test pattern, p_{min} , and the number of test patterns whose appearance probabilities belong to the range $[p_{min}; 2p_{min}]$. The theoretical results were confirmed by simulation. The results obtained in this chapter can be used to estimate the level of random pattern testability of logic blocks of micropipelines which can be incorporated into asynchronous VLSI designs and BIST structures.

Chapter 8 : Special aspects of random testing of asynchronous circuits

8.1 Probabilistic properties of the Muller-C element

Let us consider the two-input Muller-C element. Its output $c(t)$ is high at time t if both the inputs are high ($a \cdot b$) or if it is already high ($c(t-1) = 1$) and one of the inputs is still high:

$$c(t) = a \cdot b + a \cdot c(t-1) + b \cdot c(t-1), \quad (20)$$

where a and b are the inputs of the Muller-C element.

A possible implementation of the function of the two-input Muller-C element is shown in Figure 8.1. Let us estimate the output signal probability of the two-input Muller-C element when the signal probabilities of its inputs, p_a and p_b , are given. It is known that in order to calculate the output signal probability of a Boolean function, say f , with n inputs it is necessary:

- 1) to find a cover F which is a set of cubes each of which contains n literals;

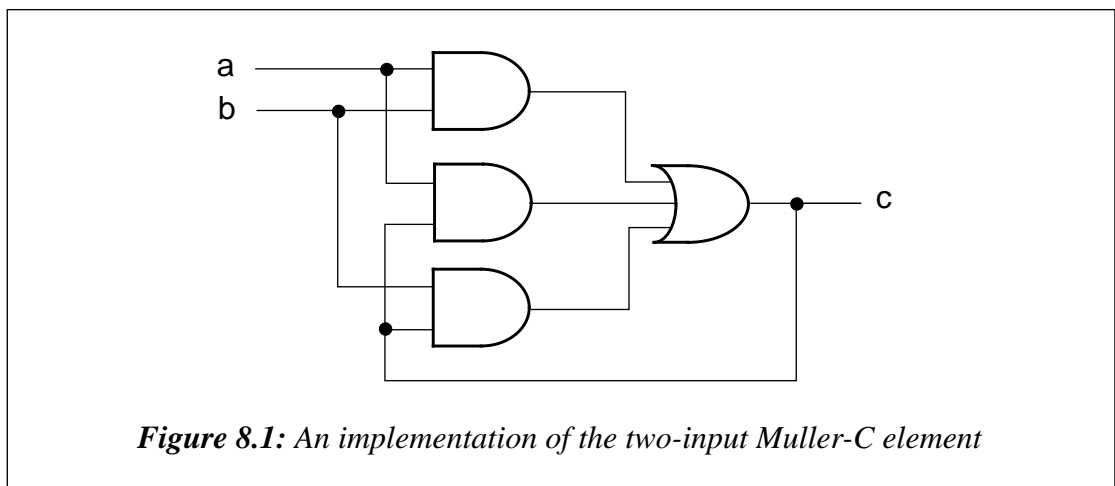

2) to calculate the probabilities of each cube of F and find the sum of these probabilities [61-63]. In the case of the two-input Muller-C element, its Boolean function (20) can be written as:

$$c(t) = a \cdot b \cdot c(t-1) + a \cdot b \cdot \bar{c}(t-1) + \bar{a} \cdot b \cdot c(t-1) + a \cdot \bar{b} \cdot c(t-1). \quad (21)$$

To calculate the output signal probability of a network with feedback it is assumed that all the signals of the feedback lines have equal probabilities since probability by definition is an average estimation of the signal frequency. Thus, the probability of a one (zero) of on line c of the Muller-C element (as shown in Figure 8.1 line c is the output and one of the inputs of the Muller-C element simultaneously) is the same, that is $p(c(t)) = p(c(t-1)) = p_c$ ($q(c(t)) = q(c(t-1)) = q_c$). Therefore, the output signal probability of the two-input Muller-C element can be found from (21) as follows:

$$p_c = p_a \cdot p_b \cdot p_c + p_a \cdot p_b \cdot q_c + q_a \cdot p_b \cdot p_c + p_a \cdot q_b \cdot p_c,$$

where p and q are the probabilities of a one and zero respectively.

Taking into account that $p + q = 1$ the probability of a one signal on the output of the two-input Muller-C element can be found:

$$p_c = p_a \cdot p_b / (1 - q_a \cdot p_b - p_a \cdot q_b). \quad (22)$$

The probability of a zero on the output of the Muller-C element can be calculated as follows: $q_c = 1 - p_c$. It is assumed that input test signals are independent, therefore, the following equation takes place: $p_a \cdot p_b + q_a \cdot p_b + p_a \cdot q_b + q_a \cdot q_b = 1$, i.e. the appearance of each combination of two-bit input vectors is an independent event and all these events are mutually exclusive ones. Thus, the probability of a zero signal on the output of the Muller-C element can be estimated with the help of the following expression:

$$q_c = q_a \cdot q_b / (1 - q_a \cdot p_b - p_a \cdot q_b). \quad (23)$$

It is easy to check that the sum of the equations (22) and (23) is equal to 1.

Making an analysis of expressions (22) and (23) the following probabilistic properties of the two-input Muller-C element can be noted:

1. If the probability of a 1 on at least one of the two inputs of the Muller-C element is equal to one then the output probability of a 1(0) is equal to one (zero). This can be proved easily by placing ones into equations (22) and (23) instead of p_a or p_b . Similarly, if the probability of a 0 on at least one of the two inputs of the Muller-C element is equal to one then the output probability of a 1(0) is equal to zero (one). This is easy to check by replacing q_a or q_b by ones into equations (22) and (23).

This property proves that from the probabilistic point of view a stuck-at-1 (stuck-at-0) fault on at least one of the inputs of the Muller-C element is equivalent to a stuck-at-1 (stuck-at-0) fault on its output.

2. If one input signal of the two-input Muller-C element has equal probabilities of a 1 and 0 then the output signal probability is equal to the signal probability of the other input of the two-input Muller-C element.

Proof. Let p_a be equal to 0.5 ($q_a=0.5$). Then $p_c = 0.5 \cdot p_b / (1 - 0.5 \cdot (p_b + q_b)) = p_b$.

Consequence. If both input signals of the Muller-C element are equiprobable and independent then a sequence of equiprobable signals is generated on its output.

From the probabilistic point of view this property can be explained as the follows: if the signal probability of one of the inputs of the two-input Muller-C element is 0.5 then the Muller-C element is transferred into a line which connects its other input and the output.

The probabilistic properties of the two-input Muller-C element can be generalized for the n -input Muller-C element:

1. If the probabilities of a 1(0) on k inputs of the n -input Muller-C element ($1 \leq k \leq n$) are the same and equal to 1 then the output probability of a 1(0) is equal to 1. That is stuck-at-1 (stuck-at-0) faults on k inputs of the n -input Muller-C element ($1 \leq k \leq n$) are

equivalent to a stuck-at-1 (stuck-at-0) fault on its output from the probabilistic point of view.

The proof of this property is trivial if the n -input Muller-C element is considered as a set of two-input Muller-C elements connected as a tree.

2. If $(n-1)$ input signals of the n -input Muller-C element are equiprobable and independent then the output signal probability is equal to the signal probability of the other input of the n -input Muller-C element.

Proof. The output signal probability of the n -input Muller-C element can be estimated as:

$$p_c = p_1 \cdot p_2 \cdot \dots \cdot p_n / (p_1 \cdot p_2 \cdot \dots \cdot p_n + q_1 \cdot q_2 \cdot \dots \cdot q_n), \quad (24)$$

where $p_1 \cdot p_2 \cdot \dots \cdot p_n + q_1 \cdot q_2 \cdot \dots \cdot q_n = 1 - q_1 \cdot q_2 \cdot \dots \cdot p_n - \dots - p_1 \cdot p_2 \cdot \dots \cdot q_n$.

Let $p_2 = p_3 = \dots = p_n = 0.5$ ($q_2 = q_3 = \dots = q_n = 0.5$) then substituting the variables of equation (24) with their appropriate values the following equation is derived:

$$p_c = p_1 \cdot 0.5^{n-1} / ((p_1 + q_1) \cdot 0.5^{n-1}) = p_1.$$

This equation proves the validity of the property.

8.2 Random testing of asynchronous control circuits

As the Muller-C element is used frequently in designing asynchronous control circuits let us consider how it is possible to test it using random patterns.

8.2.1 Random testing of the Muller-C element

Lemma. To detect all stuck-at-0 (stuck-at-1) faults of the n -input Muller-C element it is sufficient to apply a set of two test patterns to its inputs: the first pattern includes n zeros (ones) and the second one includes n ones (zeros).

Proof.

Single stuck-at faults.

A stuck-at-0 (stuck-at-1) fault on the output of the n -input Muller-C element can be tested by only one pattern which consists of n ones (zeros).

A stuck-at-0 (stuck-at-1) fault on one of the inputs of the n -input Muller-C element can be detected by the pair of patterns. The first pattern must set the Muller-C element to zero (one) state which can be done by applying logical zero (one) signals to all the inputs. The second pattern must set the Muller-C element to one (zero) state by applying logical ones (zeros) to all its inputs. As a result, a faulty Muller-C element with a stuck-at-0 (stuck-at-1) fault on one of its inputs can be identified by non-changing output signals. It is necessary to note that the order of the tests is significant.

Multiple stuck-at faults.

It is easy to check that the case of the presence stuck-at-0 (stuck-at-1) faults on k inputs of the n -input Muller-C element ($1 \leq k \leq n$) is equivalent to the case of a single stuck-at fault. Hence, a faulty behaviour of the n -input Muller-C element can be identified by the same set of test patterns.

In the case of multiple stuck-at-0 and stuck-at-1 faults a faulty n -input Muller-C element will never change its state which can be detected by applying all 0s and all 1s test patterns with no regard to their order.

Thus, the set of all 1s and all 0s tests can detect all stuck-at faults of the n -input Muller-C element.

Let us estimate the optimal output signal probabilities of the PRPG used for the random testing of the n -input Muller-C element. It is assumed that the probabilities of input signals are equal, i.e. $p_1 = p_2 = \dots = p_n = p$. Using the results of the lemma proved above and the assumption of the independence of all the input test signals the probability

of the pair of the test patterns for the detection of all stuck-at faults of the n -input Muller-C element can be found as:

$$R(p) = p_c \cdot q_c = \frac{g^n(p)}{(1-f(p))^2},$$

where $g(p) = p \cdot (1-p)$ and $f(p) = \sum_{i=1}^{n-1} C_n^i \cdot p^i \cdot (1-p)^{n-i}$ ($0 < g(p), f(p) < 1$).

For the optimal signal probability, p_o , the following expression must be true: $R(p_o) = \max$, i.e. it is necessary to find such value for variable p in which function $R(p)$ has its maximum.

The maximum of $R(p)$ is determined by the maximums of functions $g(p)$ and $f(p)$. It is known that the maximum of function $f(p)$ is reached when $p=0.5$ [60]. To find the extremum of function $g(p)$ it is necessary to solve the following equation: $\dot{g}(p) = 0$, i.e. $1 - 2 \cdot p = 0$ or $p=0.5$. It is easy to check that $p=0.5$ is the maximum of $g(p)$. Analysing the results derived above it becomes clear that there is only one maximum of function $R(p)$ which is reached when $p=p_o=0.5$.

Thus, the optimal random test procedure for the testing of the n -input Muller-C element is random testing by using equiprobable input signals. In this case the output signal probability of the n -input Muller-C element is equal to 0.5.

8.2.2 Random testing of a certain class of asynchronous circuits

Figure 8.2 shows a general structure of asynchronous control logic without feedback. For the sake of simplicity this circuit contains one two-input Muller-C element fed by the outputs of two combinational logic blocks, CL1 and CL2. Combinational logic block CL3 produces the final result of the asynchronous circuit. Let us consider how it is possible to test single stuck-at faults in this asynchronous logic.

Single stuck-at faults of the combinational logic circuits.

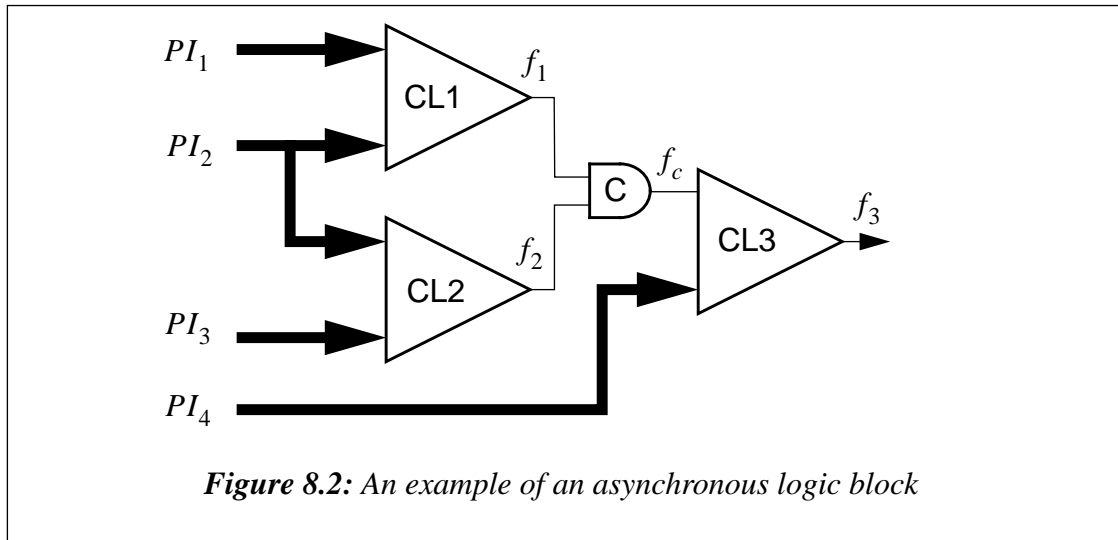

These kinds of faults can be tested by the modified D-algorithm [47]. For example, if it is necessary to propagate a zero (one) effect of the fault of one of the two combinational networks, CL1 or CL2, then:

- 1) the Muller-C element must be set to one (zero) state by manipulating primary inputs PI_1 , PI_2 and PI_3 ;
- 2) zero (one) effect must be propagated from the output of the faulty combinational network through the Muller-C element by setting the other its input to a logical zero (one) which can be done by controlling inputs PI_1 , PI_2 and PI_3 ;
- 3) the fault effect must be propagated to output f_3 of CL3 by driving inputs PI_4 .

As a result it is necessary to apply two patterns to detect a single stuck-at fault in one of combinational logics CL1 and CL2.

A single stuck-at fault of combinational circuit CL3 can be detected easily by setting the Muller-C element to the appropriate state (the manipulation of inputs PI_1 , PI_2 and PI_3) and applying an appropriate test vector on inputs PI_4 . This procedure can be done by applying only one pattern to the inputs of the asynchronous circuit under test.

Single stuck-at faults of the Muller-C element.

To test a stuck-at-0 (stuck-at-1) fault on the output of the Muller-C element it is enough to use only one test pattern which sets the Muller-C element to one (zero) state and makes its output observable on the output of the asynchronous logic under test. Stuck-at faults on inputs of the Muller-C element are tested by two test patterns: the first one sets the Muller-C element to zero (one) state and the second test pattern sets the Muller-C element to one (zero). Inputs PI_4 are driven into the appropriate logic values to propagate the state of the Muller-C element to the output of the asynchronous logic under test.

Thus, to test a single hard-to-detect stuck-at fault in the asynchronous logic circuit shown in Figure 8.2 two test patterns must be applied sequentially. This result can be generalized easily for the case of asynchronous logic circuit without feedback with any number of Muller-C elements.

Test lengths for the exhaustive random testing of this kinds of asynchronous circuits are much more longer than in the case of exhaustive random testing of simple combinational circuits. This is because all the mutual combinations of two test vectors must be generated on the inputs of the asynchronous circuit under test.

As an alternative to the traditional random testing technique where a parallel signature analyser is used for collecting the responses from the CUT a set of counters can be used for estimating signal probabilities in the nodes of the CUT [61-63].

During the test n ($n \rightarrow \infty$) random test patterns are applied to the inputs of the circuit. The probability of a one in node i , $p_i(n)$, is estimated by dividing the total number of ones registered in node i by the total number of random patterns applied. To estimate a range for the good node signal probability (the probability of a one in node i of the good circuit) during the random testing the Laplace integral theorem can be used [59,60], i.e.

$$P\left(\left|\frac{p_i(n) - p_i}{\sqrt{p_i q_i / n}}\right| \leq x\right) \rightarrow \int_{-x}^x \phi(t) dt = \Phi(x) - \Phi(-x) = 2\Phi(x) - 1, \quad (25)$$

where p_i (q_i) is the theoretical good probability of a one (zero) in node i ;

$P\left(\left|\frac{p_i(n) - p_i}{\sqrt{p_i q_i/n}}\right| \leq x\right)$ is the probability that $-x \leq (p_i(n) - p_i) / (\sqrt{p_i q_i/n}) \leq x$;

$$\Phi(x) = \int_{-\infty}^x \varphi(t) dt = \frac{1}{\sqrt{2\pi}} \int_{-\infty}^x \exp(-t^2/2) dt \text{ is Gauss' integral function.}$$

The values of Gauss' integral function for different arguments can be found in special tables [60].

Probability $p_i(n)$ calculated during the random testing can belong to a certain range with a certain probability. Hence, equation (25) must be equal to the predetermined confidence probability, p_c . Thus, argument x can be found from (25) as

$$x = \arg\Phi((1 + p_c)/2), \quad (26)$$

where $\arg\Phi(y)$ is the argument of Gauss' integral function for which $\Phi(x) = y$.

Using equations (25) and (26) the range for the good signal probability of node i of the circuit under random test is estimated as follows:

$$p_i - x(p_c) \sqrt{\frac{p_i q_i}{n}} \leq p_i(n) \leq p_i + x(p_c) \sqrt{\frac{p_i q_i}{n}}. \quad (27)$$

For example, if $p_c=0.999$ then using equation (26) and the tables for the values of function $\Phi(x)$ it can be easily found that $x=3.5$. Therefore, inequality (27) can be written as

$$p_i - 3.5 \cdot \sqrt{\frac{p_i q_i}{n}} \leq p_i(n) \leq p_i + 3.5 \cdot \sqrt{\frac{p_i q_i}{n}}.$$

Apparently, the larger n , the closer the value of the signal probability calculated during the random test to the theoretical signal probability.

The theoretical signal probabilities of nodes for the good combinational networks can be derived by known techniques [61-63]. Table 8.1 contains the equations for calculating theoretical probabilities of a one and zero on outputs of some basic logic elements. It is assumed that all the inputs of the logic elements are independent. These equations can

be used for the computation of the theoretical signal probabilities in the nodes of the circuit under random test.

Table 8.1: Equations for calculating theoretical probabilities of a one and zero of basic logic elements

Logic element	p	q
Inverter	$1 - p_1$	p_1
n -input AND gate	$\prod_{j=1}^n p_j$	$1 - \prod_{j=1}^n p_j$
n -input OR gate	$1 - \prod_{j=1}^n (1 - p_j)$	$\prod_{j=1}^n (1 - p_j)$

Figure 8.3 shows an asynchronous logic without feedback for random pattern testability. A multiplexer is inserted into the asynchronous logic to provide for its random pattern testability by connecting either the additional test input or the output of CL2 to the input of the Muller-C element. The signal probability on the output of the multiplexer is estimated on the additional test point, TP. The output signal probability of the asynchronous logic under random test is calculated as well.

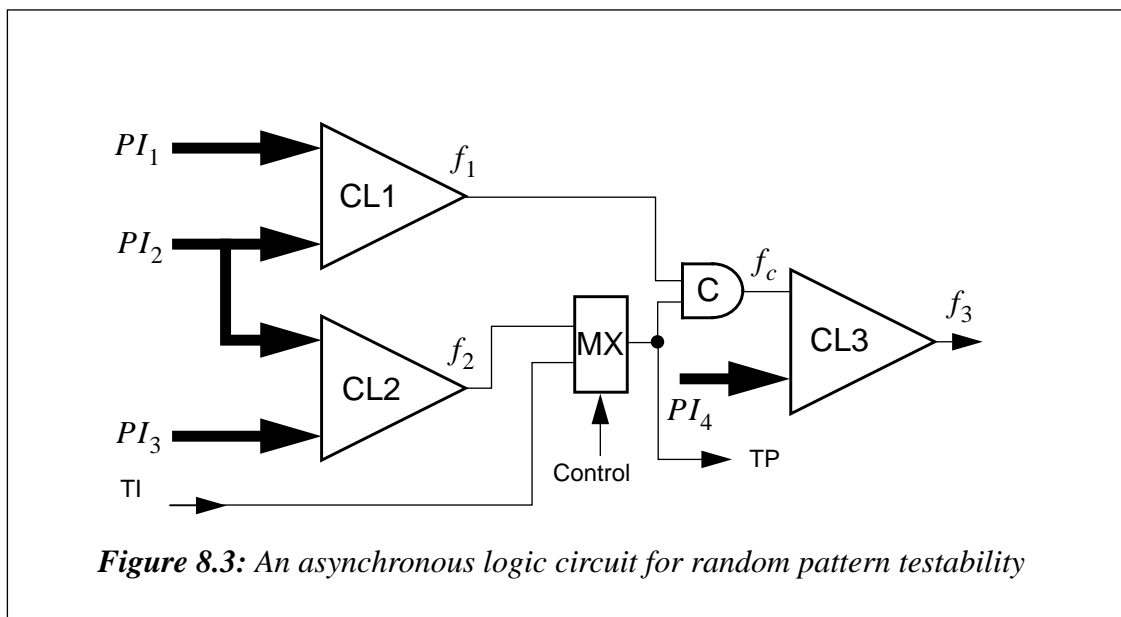

In *the normal operation mode* the control signal of the multiplexer is set to connect the output of CL2 with the input of the Muller-C element. In this case additional input TI and output TP are not used.

Random test procedure. During the random test operation mode all the inputs (including test input TI) are coupled to the outputs of the PRPG. Outputs TP and f_3 are connected to the counters which calculate the number of ones on each output.

First test phase. In the first phase of the random testing procedure node f_2 is connected to the input of the Muller-C element. The random patterns are applied to the inputs of the CUT. The signal probability on output TP (the output of combinational logic CL2) is calculated.

Second test phase. In the second random test phase the test input is connected to the input of the Muller-C element. The set of random patterns are applied to the inputs of the CUT. Due to the probabilistic property of the Muller-C element $p(f_1) = p(f_c)$ since $p(TP) = 0.5$ during the random testing. This means that from the probabilistic point of view combinational circuits CL1 and CL3 can be treated as one combinational network to derive the good signals probabilities in its nodes during the random testing. The output signal probability of this combinational circuit is calculated on output f_3 .

After the random testing if at least one of the signal probabilities derived on the observable outputs (f_3 and TP) is out of the ranges for the good signal probabilities then the circuit is faulty, otherwise it is good.

The main advantages of the technique described above are that:

- 1) the additional hardware inserted into the circuit to provide its testability is tested during the random testing;
- 2) it allows the avoidance of a very complicated procedure for calculating theoretical good signal probabilities in nodes of circuits with reconvergent fanouts.

In the case of the asynchronous circuit shown in Figure 8.3 the reconvergent fanouts are formed by primary inputs PI_2 , nodes f_1, f_2 and the output of the Muller-C element. The technique for designing asynchronous logic circuits for random pattern testability can be generalised for any number of Muller-C elements. The major disadvantage of this approach is that the extra hardware inserted into the circuit incurs additional delays which must be taken into account during the design process.

8.3 Generating patterns for the pseudo-random testing of micropipelines and asynchronous control circuits

It was mentioned above that single stuck-at faults in some types of asynchronous circuits (see Figure 8.2) can be tested by two patterns to be applied sequentially. In addition, single stuck-at-pass faults of micropipelines can be detected by pairs of tests. This property requires an answer to the question: “Is it possible to design the structure of a PRPG which can generate multi-bit pseudo-random sequences with all possible combinations of two multi-bit vectors in them?”

It appears that the pseudo-random generator used for the exhaustive testing of digital circuits (see Figure 3.4) is able to produce the pseudo-random sequences which have this property. Figure 8.4 shows the structure of a generator which includes the LSFR with a period of 2^N clocks. Only even or odd outputs of the LFSR must be used as the outputs of the generator.

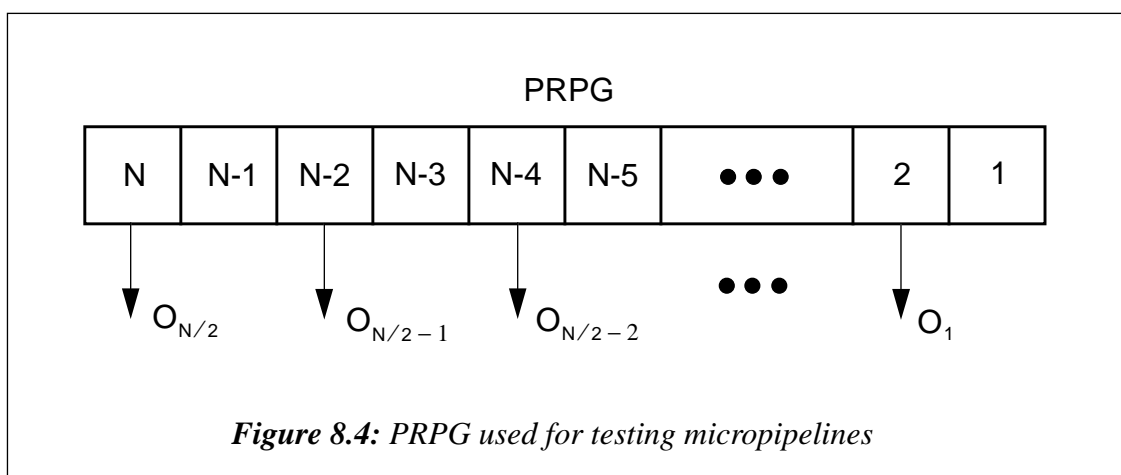

Table 8.2: State sequence for the two-bit PRPG

State	Q_4	Q_3	Q_2	Q_1	O_2	O_1	State	Q_4	Q_3	Q_2	Q_1	O_2	O_1
0	0	0	0	0	0	0	9	1	1	0	1	1	0
1	1	0	0	0	1	0	10	0	1	1	0	0	1
2	1	1	0	0	1	0	11	0	0	1	1	0	1
3	1	1	1	0	1	1	12	1	0	0	1	1	0
4	1	1	1	1	1	1	13	0	1	0	0	0	0
5	0	1	1	1	0	1	14	0	0	1	0	0	1
6	1	0	1	1	1	1	15	0	0	0	1	0	0
7	0	1	0	1	0	0	16	0	0	0	0	0	0
8	1	0	1	0	1	1	17	1	0	0	0	1	0

The multi-bit pseudo-random sequence generated on the outputs of this PRPG has the property that during the period of the LFSR it is possible to find all 2^N combinations of two $(N/2)$ -bit vectors inside the sequence.

Table 8.2 contains the states of the 4-bit LFSR and the outputs of the PRPG shown in Figure 8.4 for 18 clocks. The PRPG uses the fourth and the second outputs of the LFSR for generating a two-bit pseudo-random sequence (columns headed as O_1 and O_2). The 4-bit LFSR starts to generate pseudo-random patterns from zero state. During the period of the 4-bit LFSR (16 clocks) all the combinations of 2-bit vectors are generated inside this sequence. For instance, the combinations: 00 00, 00 01, 00 10 and 00 11 can be found easily in the output sequence. This is true for any other combinations of two 2-bit vectors in which 01, 10 or 11 takes first place.

Thus, pseudo-random patterns generated by the proposed PRPG can be used effectively for detecting all kinds of single stuck-at faults in micropipelines and asynchronous control circuits without feedback. It should be noted that the micropipeline is tested exhaustively since besides the generation of all possible binary vectors for the exhaustive testing of the logic blocks of the micropipeline all the combinations of two $(N/2)$ -bit

vectors are produced by the generator for the detection of all single stuck-at-pass faults in the latches.

Chapter 9 : Conclusions and further work

9.1 Conclusions

Asynchronous VLSI design is becoming a subject of intensive research because of the possibility of achieving higher performance and lower power consumption on the asynchronous chip in comparison with its synchronous equivalent. More accurately, synchronous design is a special case representing a single point in a multi-dimensional asynchronous world. There are several approaches to the design of asynchronous digital circuits. The bounded-delay model is the most attractive approach since it allows for the design of complex asynchronous networks by using fundamental principles for designing digital circuits and a pipelined approach.

The micropipelined approach used by the AMULET group in the design of an asynchronous version of ARM6 is based on a convention where the data is encoded normally but is bundled together with control signals called “request” and “acknowledge”. Once designed it is necessary to ensure that a physical implementation of such a microprocessor will work correctly. This can be achieved by applying a set of test patterns to its inputs and observing the responses on the outputs. The asynchronous implementation of ARM6 is more complicated than the synchronous one which aggravates the test problems significantly.

As was shown, the major difficulties in testing both synchronous and asynchronous VLSI circuits are similar. The general fault models which can be used for representing fault effects in asynchronous VLSI designs are stuck-at faults, bridging faults, stuck-open faults and delay faults. Each kind of fault manifests itself differently in asynchronous networks than in synchronous circuits and this requires a more detailed analysis to

be done in order to derive effective test vectors. In bounded-delay asynchronous designs, delay faults are the source of the most difficult test problems to be solved.

Random (pseudo-random) testing is becoming a viable alternative to deterministic test generation methods for the following reasons:

- the test sequence applied to the inputs of the VLSI circuit does not depend on its specification and can be used for all the circuits to be tested;
- pseudo-random pattern generators are simple and can be used successfully in asynchronous built-in self-test structures.

The majority of DFT methods have been developed to ease the generation and application of test vectors to synchronous circuits. Three groups of DFT techniques can be distinguished: ad hoc strategies, structured approaches and built-in self-test techniques. The most popular DFT methods allow for the separation of the combinational part of the circuit from the memory elements during the test. A particular DFT method can solve a subset of the test problems concerned with the circuit to be tested. The advantages of DFT methods for VLSI circuits cannot be achieved without a cost measured usually in terms of silicon overhead, performance degradation and reduction in reliability.

Testing asynchronous VLSI circuits is a difficult problem mainly because of the different approaches to designing these kinds of networks whereas the majority of test generation methods have been devised for testing synchronous circuits. Analysis of work in the field of testing asynchronous VLSI circuits shows that there are two main directions to solve this problem:

- adapting existing test generation techniques for testing synchronous VLSI circuits to test asynchronous ones;
- deriving new test generation approaches to testing asynchronous VLSI circuits.

Recent results in the testing of micropipelines show that the test procedure of such asynchronous designs must include the testing of both the control part and the data paths of

the micropipeline under test. It was proved that single stuck-at faults in the control circuits of the micropipeline are tested during the normal operation mode whereas two test patterns are required to detect those faults in the data paths of the micropipeline.

An asynchronous random testing interface has been described in this thesis. It includes an asynchronous pseudo-random pattern generator and an asynchronous parallel signature analyser. The correctness of the structures proposed has been checked using standard CAD tools for simulating hardware designs. A program model of the universal pseudo-random pattern generator has been developed. This generator can produce multi-bit pseudo-random sequences without the obvious shift operation, and can also produce weighted pseudo-random test patterns.

In this thesis, mathematical expressions have been derived for predicting test lengths for the random pattern testing of micropipelines by using equiprobable and weighted test patterns. It was shown that to estimate the lower bound for the test length using equiprobable random test patterns it is possible: 1) to use the assumption that appearances of all test patterns are mutually exclusive events and 2) to exploit the Poisson approximation for calculating the probabilities of these events. It was proved that to evaluate more exactly the lower bound for the test length for random testing a combinational network by means of weighted test patterns it is sufficient to take into account the probability of the rarest test pattern, p_{min} , and the number of test patterns whose appearance probabilities belong to the range $[p_{min}; 2p_{min}]$. The theoretical results have been confirmed by simulation.

The probabilistic properties of the n -input Muller-C element have been investigated. It was proved that from the probabilistic point of view:

- stuck-at-1 (stuck-at-0) faults on k inputs of the n -input Muller-C element ($1 \leq k \leq n$) are equivalent to a stuck-at-1 (stuck-at-0) fault on its output;
- if $(n-1)$ input signals of the n -input Muller-C element are equiprobable and independent then the Muller-C element can be considered as a line which connects its other input and the output.

It was shown that the optimal random test procedure for the testing of the n -input Muller-C element is random testing by using equiprobable input signals. Using the probabilistic properties of the Muller-C element and multiplexers incorporated into the circuit a certain class of asynchronous networks can be designed for random pattern testability.

It was shown how it is possible to produce pseudo-random patterns to test micropipelines exhaustively. The LFSR generating all possible binary vectors is used as a source of test patterns. To provide the pseudo-exhaustive testing of the micropipeline it is necessary to use only even (odd) outputs of such an LFSR.

9.2 Future work

The work presented in this thesis will provide a basis for my future research. I intend to continue my work in the field of the random testing of bounded-delay asynchronous circuits. The main directions of my future research are the following:

- investigating fault effects and elaborating more accurate fault models which may be different from the classical fault models but must reflect the appropriate technological properties of asynchronous VLSI circuits;
- investigating the behaviour of real asynchronous VLSI circuits (the circuits designed by the AMULET research group) to be tested by equiprobable and weighted random (pseudo-random) patterns;
- working out techniques for the effective testing of delay faults in the data paths and control circuits of micropipelines;
- developing techniques for estimating the degree of random pattern testability of asynchronous VLSI circuits;
- research on asynchronous VLSI designs for random pattern testability in a scan environment;

- developing asynchronous built-in self-test VLSI structures;
- designing a real chip for random pattern testability and estimating its characteristics in terms of hardware redundancy, performance and reliability.

Appendix A : Asynchronous 4-bit PRPG

A.1 Schematic of the generator

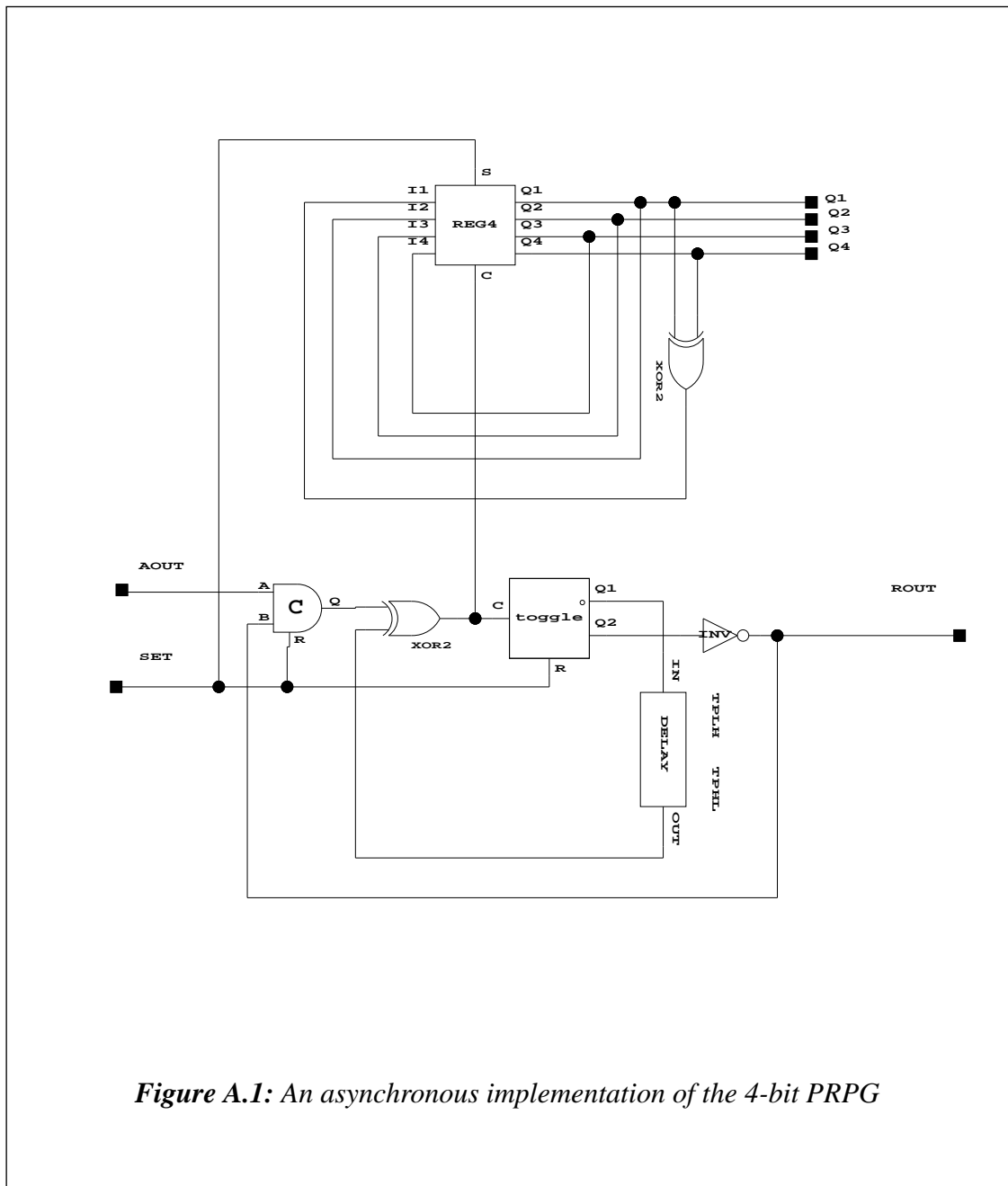

Figure A.1: An asynchronous implementation of the 4-bit PRPG

A.2 The register of the generator

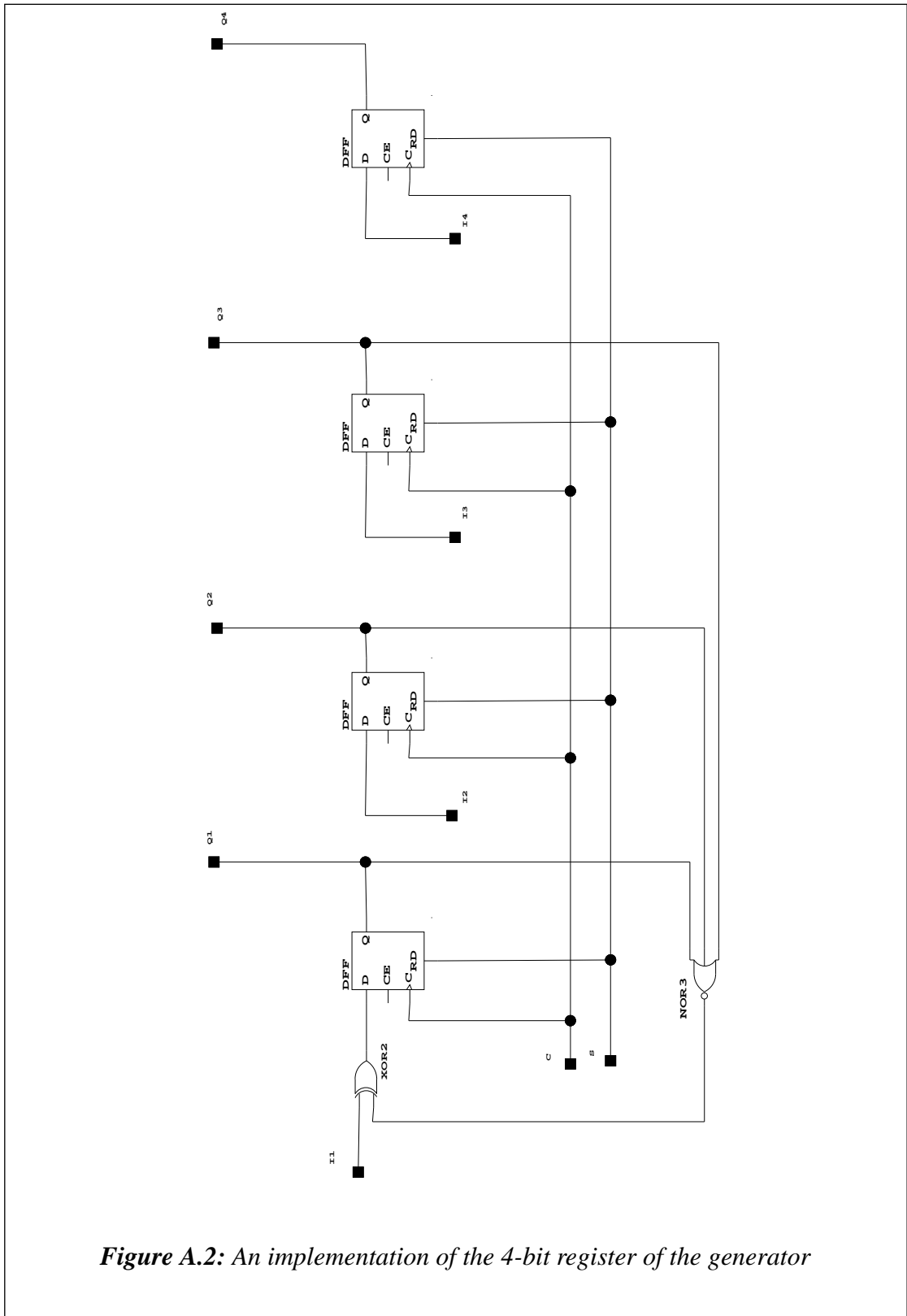

Figure A.2: An implementation of the 4-bit register of the generator

A.3 Simulation results

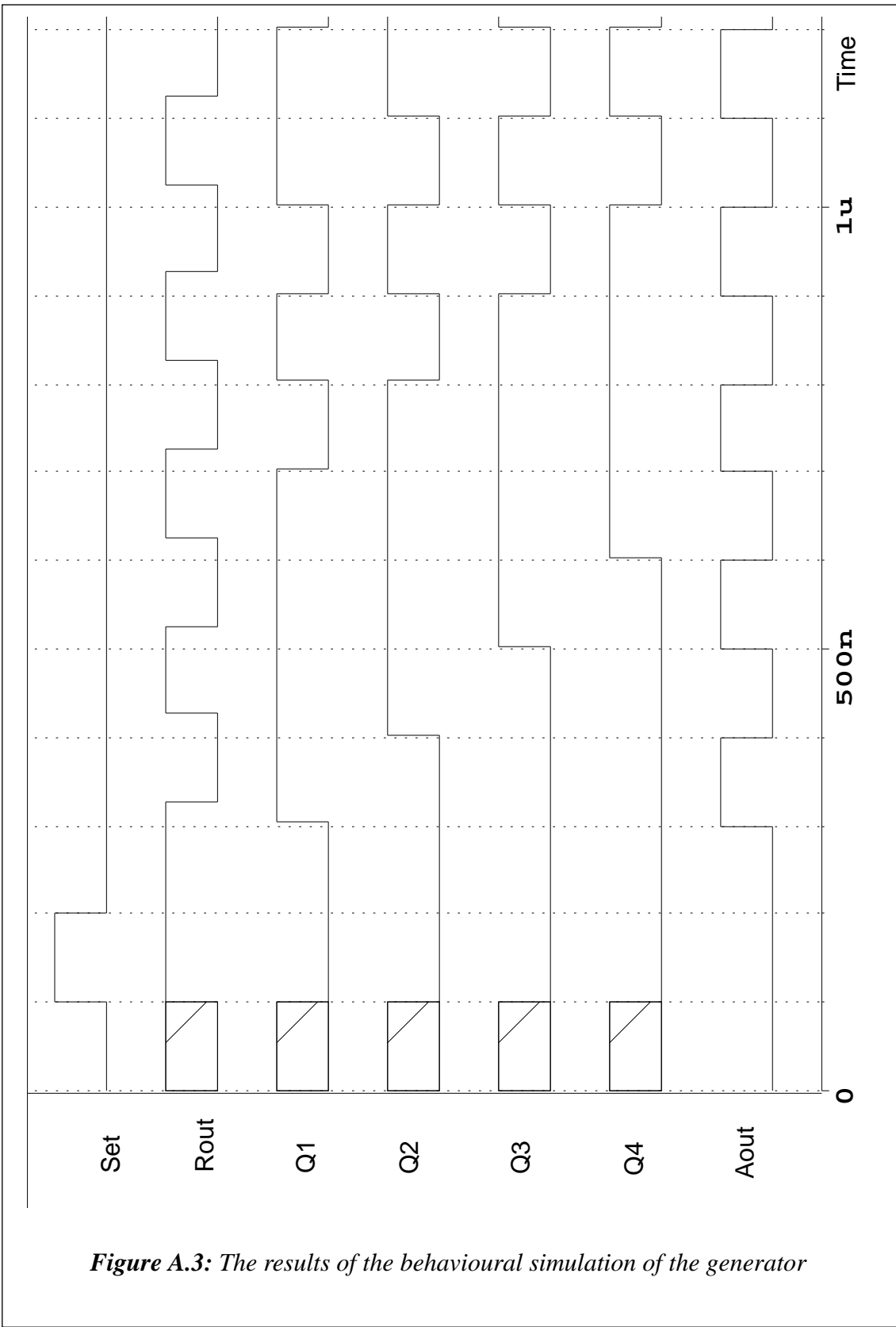

Figure A.3: The results of the behavioural simulation of the generator

Appendix B : Asynchronous 4-bit parallel signature analyser

B.1 Schematic of the signature analyser

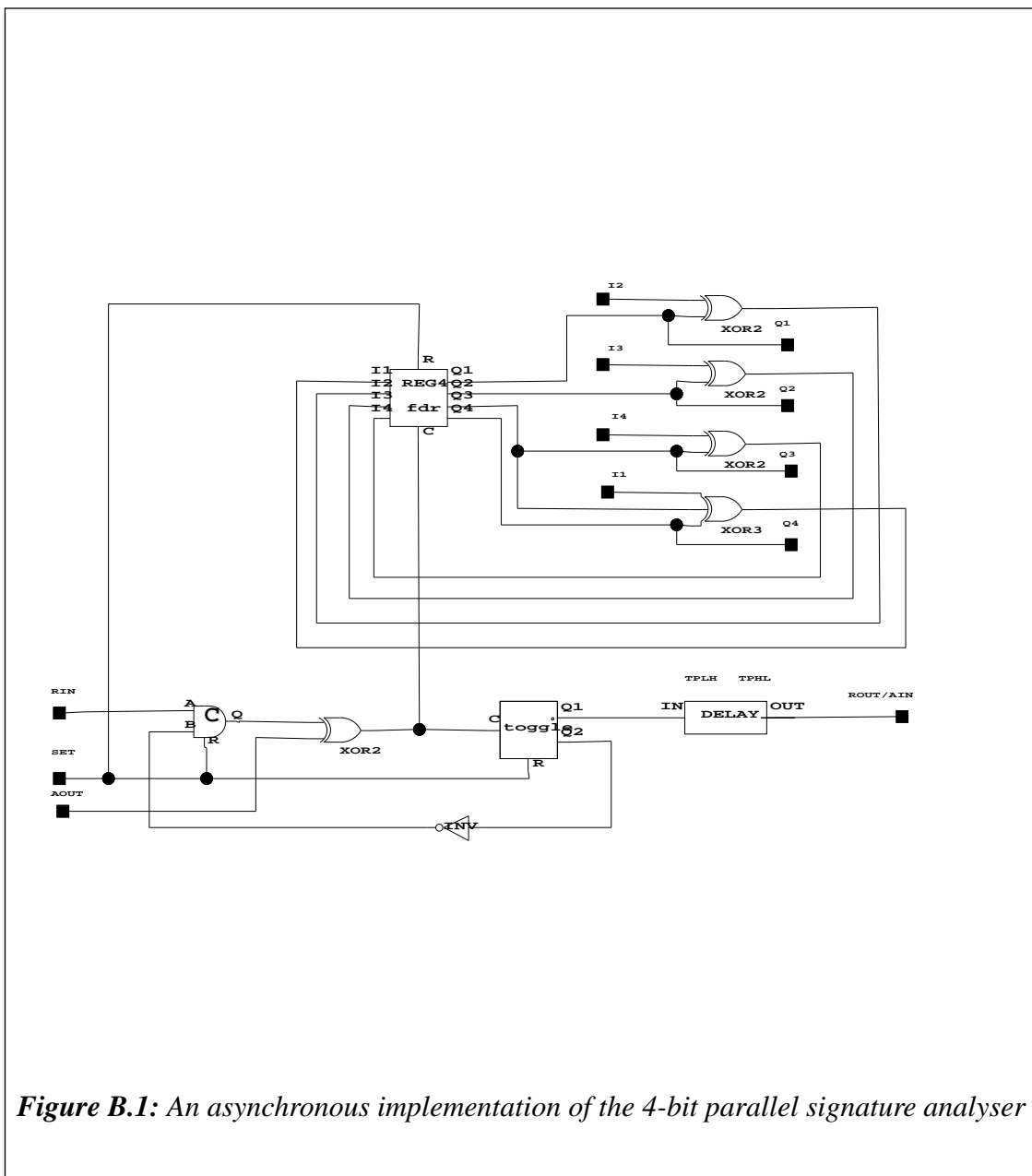

Figure B.1: An asynchronous implementation of the 4-bit parallel signature analyser

B.2 The register of the signature analyser

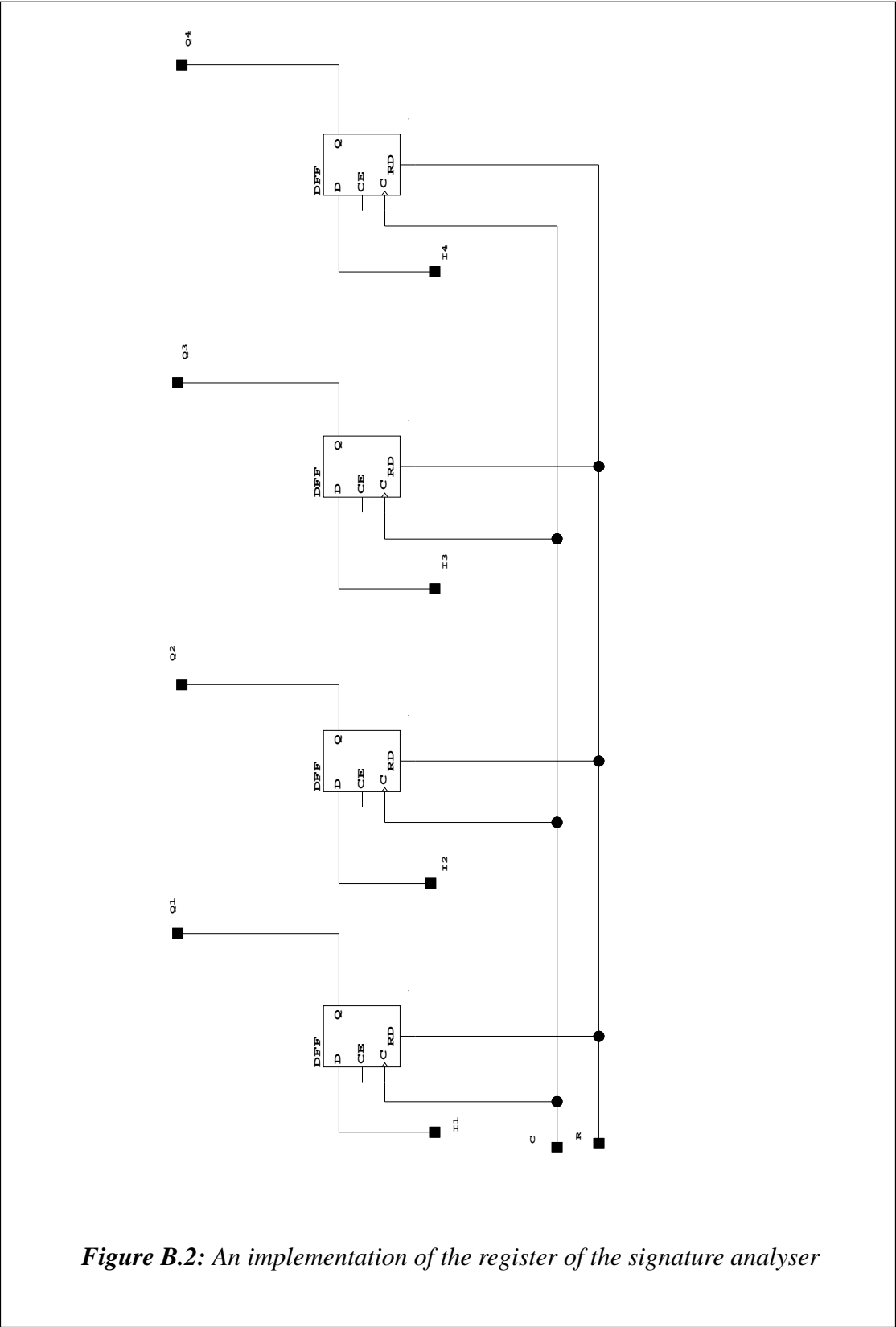

Figure B.2: An implementation of the register of the signature analyser

B.3 Simulation results

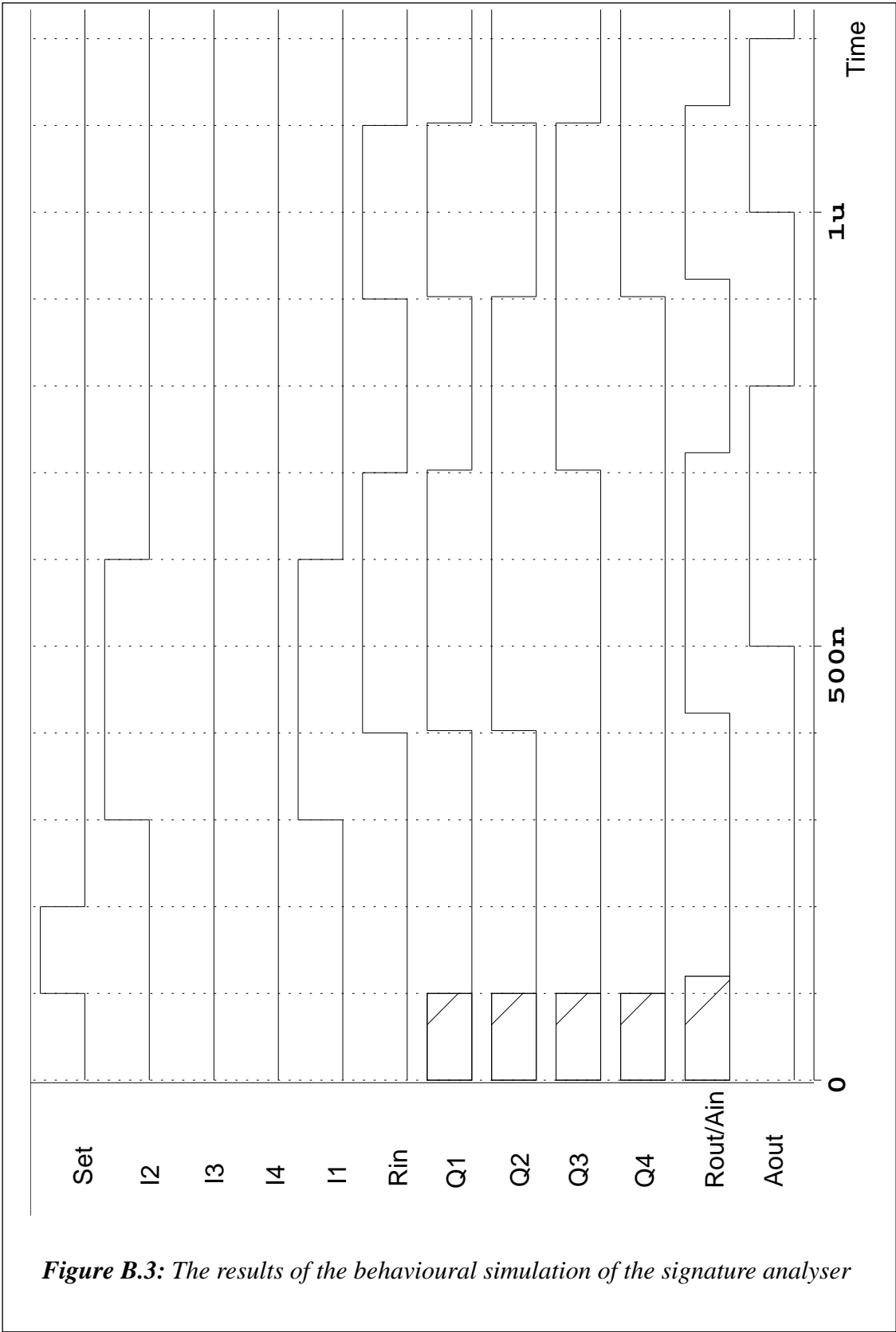

Figure B.3: The results of the behavioural simulation of the signature analyser

References

- [1] Russell G. Computer aided tools for VLSI system design. Peter Peregrinus Ltd., 1987.
- [2] Mead C., Conway L. Introduction to VLSI systems. Addison-Wesley Publishing Company, 1980.
- [3] Sutherland I.E. Micropipelines. Communications of the ACM, Vol.32, no.6, June, 1989, 720-738.
- [4] Gopalakrishnan G., Jain P. Some recent asynchronous system design methodologies. Technical Report UU-CS-TR-90-016, University of Utah, October, 1990.
- [5] Furber S. B., Day P., Garside J. D., Paver N. C., Woods J.V. A micropipelined ARM. Proceedings of of the IFIP TCWG 5th International Conference on VLSI, Grenoble, France, 6-10 September 1993, pp. 5.4.1-5.4.10.
- [6] Martin A. J., Burns S. M., Lee T. K., Borkovic D., Hazewindus P. J. Design of an asynchronous microprocessor. Advanced Research in VLSI 1989: Proceedings of the Decennial Caltech Conference on VLSI, ed. C. L. Seitz, MIT Press, 1989, pp. 351-373.
- [7] Garside J. D. A CMOS implementation of an asynchronous ALU. Proceedings of IFIP Working Conference on Asynchronous Design Methodologies / Edited by S. Furber and M. Edwards, Manchester, UK, 31 March - 2 April 1993, 1993, pp. 37-43.
- [8] Rice R. Tutorial: VLSI Support Technologies-Computer-Aided Design, Testing and Packaging. IEEE Computer Society, Los Alamitos, Calif., 1982, pp. 228-308.
- [9] Russell G., Sayers I. L. Advanced simulation and test methodologies for VLSI design. Van Nostrand Reinhold (International), 1989.
- [10] Roth J. P. Computer Logic, Testing and Verification. Pitman: Digital System Design Series, London, 1980.
- [11] Abramovici M., Breuer M., Fiedman A. D. Digital Systems Testing and Testable Design. Computer Science Press / Freeman, New York, 1990.

- [12] Cheng Kwang-Ting, Agrawal V. D. Unified Methods for VLSI Simulation and Test Generation. Kluwer Academic, Boston, 1989.
- [13] Wilkins B. R. Testing digital circuits : an introduction. Van Nostrand Reinhold (UK), 1986.
- [14] Lala P. K. Fault tolerant and fault testable hardware design. Prentice Hall (International), 1985.
- [15] Abraham J. A., Fuchs W. K. Fault and error models for VLSI. Proceedings of the IEEE, Vol.74, no.5, May, 1986, pp. 639-654.
- [16] Chen H. H., Mathews R. G., Newkirk J. A. Test generation for MOS circuits. 1984 International Test Conference, October, 1984, pp. 70-79.
- [17] Agrawal P., Agrawal V. D., Seth S. C. A new method for generating tests for delay faults in non-scan circuits. Proceedings of the Fifth International Conference on VLSI Design, Bangalore, India, January 1992, pp. 4-11.
- [18] Park E. S., Mercer M. R., Williams T. W. A statistical model for delay-fault testing. IEEE Design and Test of Computers, February, 1989, pp. 45-55.
- [19] Abadir M. S., Reghbati H.K. LSI testing techniques. IEEE Micro, February, 1983, pp. 34-51.
- [20] Muehldorf E. I., Savkar A. D. LSI logic testing - an overview. IEEE Transactions on Computers, C-30(1), 1981, pp. 1-17.
- [21] McCluskey E. J. Built-in self test structures. IEEE Design and Test of Computers, 2(2), 1985, pp. 29-36.
- [22] Ibarra O. H., Sahni S. K. Polynomially complete fault detection problems. IEEE Transactions on Computers, C-24(3), 1975, pp. 242-249.
- [23] McCluskey E. J., Bozorgui-Nesbat S. Design for autonomous test. IEEE Transactions on Computers, C-32(2), 1981, pp. 866-875.
- [24] Wagner K.D., Chin C.K., McCluskey C.J. Pseudorandom testing. IEEE Transactions on Computers, C-36(3), 1987, pp. 332-343.
- [25] David R., Thevenod-Fosse P. Random testing of integrated circuits. IEEE Transactions on Instrumentation and Measurement, Vol.IM-30(1), March, 1981, pp. 20-25.
- [26] Hewlett-Packard Ltd. A designer's guide to signature analysis. Application Note 222, 1977.

- [27] Knuth D. E. The art of computer programming. Vol. 2: Seminumerical Algorithms, Addison-Wesley Publishing Company, Inc., Reading, Mass., 1969.
- [28] McCluskey E. J. Logic design principles: with emphasis on testable semicustom circuits. Prentice-Hall International Editions, 1986.
- [29] Trivedi K.S. Probability and statistics with reliability, queuing and computer science applications. Englewood Cliffs, NJ: Prentice-Hall, 1982.
- [30] Golomb S. W. Shift register sequences. Aegean Park Press, Laguna Hills, Calif., 1982.
- [31] McCluskey E. J. Verification testing - a pseudoexhaustive test technique. IEEE Transactions on Computers, C-33(6), 1984, pp. 541-546.
- [32] Bennetts R. G. Design of testable logic circuits. Addison-Wesley Publishing Company, 1984.
- [33] Williams T.W., Parker K. P. Design for testability - a survey. Proc. IEEE, Vol.71, 1983, pp. 95-122.
- [34] McCluskey E. J. A survey of design for testability scan techniques. VLSI Design, 5(12), 1984, pp. 38-61.
- [35] Savir J., Ditlow G., Bardell P.H. Random pattern testability. Digest of Papers, 13th International Symposium on Fault Tolerant Computing, June, 1983, pp. 80-89.
- [36] Le Blanc J. J. LOCST: A built-in self-test technique. IEEE Design and Test, Nov. 1984, pp. 45-52.
- [37] Bardell P. H., McAnney W. H. Self-testing in a multi-chip logic module. International Test Conference, Oct. 1982, IEEE Pub. 82CH1808-5, 1982, pp. 200-204.
- [38] Putzolu G. R., Roth J. P. A heuristic algorithm for the testing of asynchronous circuits. IEEE Transactions on Computers, C-20(6), June 1971, pp. 639-647.
- [39] Chappell S. G. Automatic test generation for asynchronous digital circuits. The Bell System Technical Journal, Vol.53, No.8, October 1974, pp. 1477-1503.
- [40] Heard B. J., Sheshadri R. N., David R. B., Sammuli A. G. Automatic test pattern generation for asynchronous networks. 1984 International Test Conference, October 1984, pp. 63-69.
- [41] Fujieda T., Zenke N. Testing asynchronous devices. 1987 International Test Conference, 1987, pp. 871-875.

- [42] Thorel P., Rainard J. L., Botta A., Chemarin A., Majos J. Implementing boundary-scan and pseudo-random BIST in an asynchronous transfer mode switch. 1991 International Test Conference, 1991, pp. 131-139.
- [43] Bellon C., Velazco R. Taking into account asynchronous signals in functional test of complex circuits. Proceedings of the 21st Design Automation Conference, 1984, pp. 490-496.
- [44] Susskind A. K. A technique for making asynchronous sequential circuits readily testable. 1984 International Test Conference, 1984, pp. 842-846.
- [45] Li T. Design for VLSI asynchronous circuits for testability. *Int. J. Electronics*, Vol. 64, No. 6, 1988, pp. 859-868.
- [46] Keutzer K., Lavagno L., Sangiovanni-Vincentelli A. Synthesis for testability techniques for asynchronous circuits. International Conference on Computer-Aided Designs, 1991, pp. 326-329.
- [47] Hazewindus P. Testing Delay-Insensitive Circuits. PhD thesis, Caltech-CS-TR-92-14, California Institute of Technology, 1992.
- [48] Roncken M., Saeijs R. Linear test times for delay-insensitive circuits: a compilation strategy. Proceedings of IFIP Working Conference on Asynchronous Design Methodologies / Edited by S. Furber S. and M. Edwards, Manchester, UK, 31 March - 2 April 1993, 1993, pp. 13-27.
- [49] Beerel P.A., Meng T. H.-Y. Semi-modularity and self-diagnostic asynchronous control circuits. Proceedings of the Conference on Advanced Research in VLSI / editor Carlo H. Sequin, MIT Press, Santa Cruz, March 1991, pp. 103-117.
- [50] David I., Ginosar R., Yoeli M. Self-timed is self-diagnostic. Technical Report EE Pub No.758, Department of Electrical Engineering, Technion, November 1990.
- [51] Pagey S., Sherlekar S., Venkatesh G. Issues in fault modelling and testing of micropipelines, 1994, to appear.
- [52] Benowitz N., Calhoun D. F., Alderson G. E., Bauer J. E., Joeckel C. T. An advanced fault isolation system for digital logic. *IEEE Transactions on Computers*, C-21(9), 1972, pp. 1015-1017.
- [53] Agrawal P., Agrawal V. D. On Monte Carlo testing of logic tree networks. *IEEE Transactions on Computers*, C-25(6), 1976, pp. 664-667.
- [54] Waicukauski J. A., Lindbloom E., Eichelberger F. B. A method for generating weighted random test patterns. *IBM J. Res. and Dev.*, 1989, no. 2, pp. 149-161.

- [55] Virupakshia A. R., Reddy V. C. A simple random test procedure for detection of single intermittent fault in combinational circuits. *IEEE Trans. on Computers*, 1983, no. 6, pp. 594-597.
- [56] J. J. Shedletsky, Random Testing: Practicality vs. Verified Effectiveness, *Proc. Seventh Int. Conf. on Fault-Tolerant Comp.*, June 1977, pp. 175-179
- [57] Savir J., Bardell P.H. On random pattern test length. *Digest of Papers, 1983 International Test Conference*, October, 1983, pp. 95-106.
- [58] Chin C.K., McCluskey E. J. Test length for pseudorandom testing. *IEEE Transactions on Computers*, C-36(2), 1987, pp. 252-256.
- [59] Bostock L. , Chandler S. *Pure Mathematics*. Stanley Thornes (Publishers) Ltd., 1984.
- [60] Spiegel M. R. *Mathematical Handbook of Formulas and Tables*. McGraw-Hill Book Company, 1968.
- [61] Parker K.P., McCluskey E. J. Analysis of logic circuits with faults using input signal probabilities. *IEEE Transactions on Computers*, C-24(5), 1975, pp. 573-578.
- [62] Parker K.P., McCluskey E. J. Probabilistic treatment of general combinational networks. *IEEE Transactions on Computers*, C-24(6), 1975, pp. 668-670.
- [63] Seth S. C., Agrawal V. D. A new model for computation of probabilistic testability in combinational circuits. *Intergation, The VLSI Journal*, No.7, 1989, pp. 49-75.